

User Guide

G&G GG21B3A-S1-01/GG21B3A-S1A-01 Series

(GM1033 Series)

Monochrome Laser Multifunction Printer



Preface

Welcome to the G&G series products!

We heartily appreciate your using of G&G series products!

To protect your vital interests, please carefully read the following statements.

For more information, please visit our official website (www.gg-printer.ru).

Legal Notice

Trademark

Zhuhai Ninestar Information Technology Co., Ltd. has the right to use the G&G and G&G logos. Microsoft®, Windows®, Windows Server® and Windows Vista® are trademarks registered by Microsoft Corporation in the United States or other countries/regions.

Apple, AirPrint, Mac, and macOS are trademarks of Apple Inc., registered in the U.S. and other countries. Use of the Works with Apple badge means that an accessory has been designed to work specifically with the technology identified in the badge and has been certified by the developer to meet Apple performance standards.

The Mopria™ wordmark and the Mopria™ Logo are registered and/or unregistered trademarks of Mopria Alliance, Inc. in the United States and other countries. Unauthorized use is strictly prohibited.

Wi-Fi Direct, Wi-Fi Protected Setup (WPS), WPA, WPA2, WPA3 and Wi-Fi Protected Access are marks of the Wi-Fi Alliance.

The ownership to the names of the software in this User Guide belongs to their respective companies in accordance with corresponding license agreement, and they are referred for instructions only.

All other product and brand names herein may be the registered trademarks, trademarks or service marks of their respective owners, and they are referred for instructions only.

Copyright

The copyright of this User Guide is owned by Zhuhai Ninestar Information Technology Co., Ltd. It is prohibited to copy, translate, modify and transmit this User Guide by any means or forms without the prior written consent of Zhuhai Ninestar Information Technology Co., Ltd.

Version: V1.0

Disclaimer

For a better user experience, Zhuhai Ninestar Information Technology Co., Ltd. reserves the right to make changes to the User Guide. The information contained herein is subject to change without notice.

Users are responsible for any damages arising from failing to follow this User Guide. Meanwhile, except the express warranty made in the product maintenance manual or service commitment, Zhuhai Ninestar Information Technology Co., Ltd. does not make any express or implied warranty or guarantee to this User Guide (including composing or words).

Using this product to copy, print, scan certain documents or images or make other forms of operations may be prohibited by the local laws. If you are uncertain about the legality of using this product for certain documents or images, you should consult your legal advisor in advance.

Safety Precautions

Disconnect the power supply

The product should be placed close to or easily accessible to power sockets, so as to allow easy disconnection of power supply!

Laser Safety

The laser radiation is harmful to the human body. Since laser components are completely sealed in the printer, laser radiation will not leak. To avoid laser radiation, please do not randomly disassemble the printer!

Caution – Use of controls or adjustments or performance of procedures other than those specified herein may result in hazardous radiation exposure.

The printer follows the provisions of Class 1 laser products under CFR standard.



The printer has a Class 3B laser diode, which has no laser radiation leakage among laser components.

The laser components shall comply with the requirements of: U.S. Code of Federal Regulations, 21 CFR 1040, IEC 60825-1.

The following label is attached to the laser components inside the printer:











or

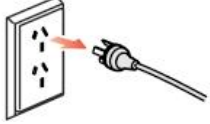

Safety Warning

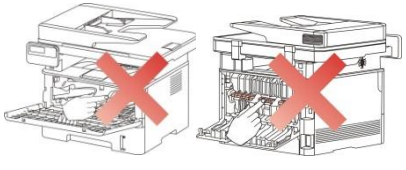
Please note the following safety warnings before using the printer:

 Warning	
 There is high-voltage electrode inside the printer. Before cleaning the printer, make sure the power is turned off!	
 Plugging and unplugging the power cord plug with a wet hand can result in an electric shock.	
 The fuser unit is hot when and after printing. Touching the fuser unit (the shaded area as shown) may cause burns!	
 The fuser unit is attached with a high temperature warning label. Please do not remove or damage this label.	

Precautions

Precautions before Using the Printer:

1. Read and understand all instructions.
2. Familiarize yourself with the basic principles associated with operating electrical appliances.
3. Comply with all warnings and instructions marked on the equipment or specified in the manual supplied with the equipment.
4. If the operating instructions conflict with the safety information, please refer back to the safety information, as you may have misunderstood the operating instructions. If you cannot resolve the conflicts, please call the Customer Service Hotline or contact a service representative for help.
5. Before cleaning the equipment, remove the power cord from the AC power supply outlet. Do not use liquid or aerosol cleaners.
6. Please make sure that the equipment is put on a stable desktop surface to avoid serious damage caused by the falling of the equipment.
7. Do not put the equipment near a radiator, an air conditioner, or a ventilation pipe.
8. Do not put any articles on the power cord. Do not put the equipment at the place where its power cord could be stepped on by people.
9. Outlets and extension cords must not be overloaded. This may reduce performance and could result in fire or electric shock.
10. Do not allow pets to chew on the AC power cord or the computer interface cable.
11. Do not allow sharp objects piercing equipment slot, so as to avoid contact with the high-voltage device, which otherwise may result in fire or electric shock. Take care not to spill liquids onto the equipment.
12. Do not disassemble the equipment so as to avoid the risk of electric shock. Necessary repairs may only be carried out by professional maintenance personnel. Opening or removing the cover could result in an electric shock or other potential hazards. Incorrect disassembly and assembly could also result in an electric shock during future use.
13. If any one of the following occurs, disconnect the equipment from the computer and pull out the power cord from the AC wall socket and contact a qualified member of the service personnel for maintenance:
 - Liquid has been spilled into the equipment.
 - The equipment has been exposed to rain or water.
 - The equipment falls, or the cover is damaged.
 - Significant changes in the equipment's performance.
14. Only adjust the control mentioned in the instructions. Incorrect adjustment of other controls may result in damage and mean that professional maintenance personnel need to spend more time fixing it.
15. Do not use the equipment in a thunderstorm so as to avoid the risk of an electric shock. If possible, pull out the AC power cord during a thunderstorm.
16. If you continuously print multiple pages, the surface of the tray will become very hot. Take care not to touch this surface, and keep children away from this surface.
17. The signal wire of the device connected with the printer can not be connected to the outdoors.
18. Please ensure timely ventilation in case of a prolonged use or printing huge amounts of documents in a poorly ventilated room.

19. In standby status, the product will automatically enter into the power saving (sleep) mode if it does not receive any job order for a while (such as 1 minute); and it can realize zero power consumption only if it has not been connected with any external input power supply.
20. As the Class 1 equipment, the product must be connected to the power supply outlet with protective grounding line when using.
21. This product should be placed according to the shipping marks on the product package box during delivery.
22. This product is a kind of low-voltage equipment. When using this product below the specified voltage range, please refer to the product precautions or call G&G Aftersales Service Centre, if the toner comes off the printed contents, or the equipment starts slowly;
23. This product is sold as a complete machine. The consumers can go to G&G Aftersales Service Centre to purchase parts they need. If the product sold is inconsistent with the package list, please go to the specified Aftersales Service Centre to solve the problem;
24. Install this product in a place with the temperature between 10°C and 32°C and the relative humidity between 20% and 80%.
25. RF Radiation Exposure Statement Caution: To maintain compliance with the RF exposure guidelines, place the product at least 20cm from nearby persons.
26. Warning: Changes or modifications to this unit not expressly approved by the party responsible for compliance could void the user's authority to operate the equipment.
27. The power consumption of the product with wireless function is 3W / without wireless function is 2.7W in networked standby if all wired network ports are connected and all wireless network ports are activated.
28. To avoid the danger of fire or electric shock, please only use the power cord provided with this product or authorized replacements approved by the manufacturer.
29. The power cord provided with this product is intended for this product only. Do not use it with other devices as it may cause fire, electric shock, or other injuries.
30. Do not use flammable sprays or combustible solvents near or inside the machine. Additionally, do not place them near or inside the machine as it may cause fire or electric shock.
31. Please keep this User Guide properly.

Legal Information



This symbol indicates that, at the end of your product's life, it must not be discarded as domestic waste. Instead, you should dispose of your used equipment at a designated collection point for the recycling of waste electrical and electronic equipment. Ref: EU Directive 2002/96/EC on Waste Electrical and Electronic Equipment (WEEE). Please contact your distributor / supplier for further information.



This product is suitable for indoor use only.

Table of Contents

01 Before Using the Printer	1
Product View	1
Control Panel	3
Overview of control panel	3
Function of status indicator	4
Function of power indicator	5
02 Paper and Print Media	6
Paper Specification	6
Loading Paper	7
Loading into the Automatic Feeder Tray	7
Install manual feed tray	9
Paper and Manuscript Use Process	10
Scanning With Tablet	11
Scan with the automatic document feeder (ADF)	13
03 Driver installation and uninstallation	14
Driver Setup	14
One-click Installation(For Windows and macOS)	14
Uninstall Driver	15
Method to uninstall driver under Windows	15
Method to uninstall driver under macOS	15
04 Wired network setup (applicable to wired network models)	16
Set IP Address	16
Automatic Setting	16
Manual Setting	16
05 Wireless network setup (applicable to Wi-Fi models)	17
Basic structure mode	17
Wireless network setup tools	18
How to disable the Wi-Fi network connected	18
06 Web server	19
Visit the embedded Web server	19
07 Print	20
Print Function	20
Print Settings	21
Setting the printing parameters	21
Automatic Two-Sided Printing	21

Mute printing	24
08 Copying	25
Copying function	25
Common copying setting	25
Multipage	26
Collated copy	27
Manual duplex copying	27
ID card copying setting	29
Receipt setting	29
09 Scan	30
Pull Scan	30
G&G Scan Application	30
macOS System Scan	31
Push Scan	31
Scan to PC	32
Scan to E-mail	32
Scan to FTP	33
Scan to U disk	33
10 Routine Maintenance	34
Cleaning the Printer	34
Toner cartridge and drum component maintenance	37
About toner cartridge and drum component component	37
Replace toner cartridge and drum component	38
11 Troubleshooting	42
Cleaning Jammed Paper	42
Middle jam	42
Paper Jam in the Fuser Unit	45
Duplex Unit Jam	47
A paper jam occurs on the automatic document feeder (ADF)	49
Software Failure	51
Error Message	52
Common Troubleshooting	53
Common Trouble	53
Image Defects	55
12 Product Specifications	59
Overview of the Specifications	59
Print Specifications	60

Copy Specifications	60
Scan Specifications	60

01 Before Using the Printer

Product View

Side view

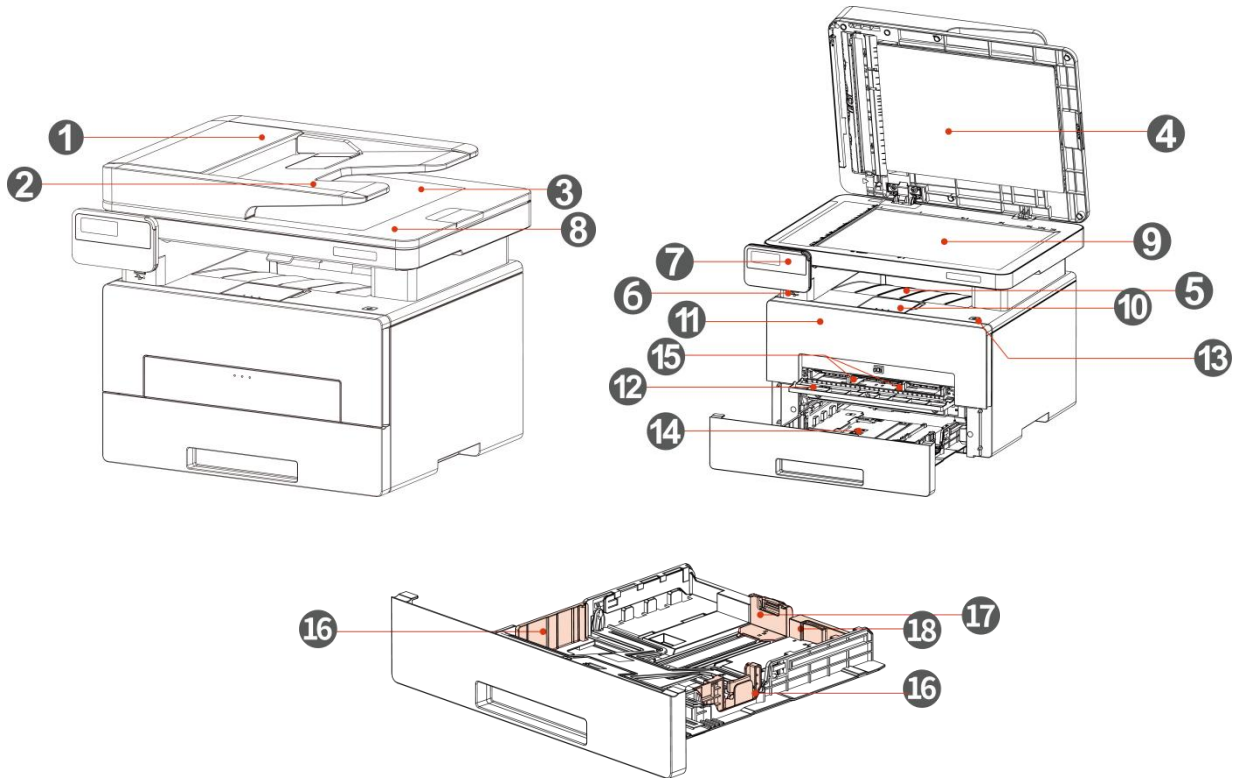

1	Cover of automatic document feeder	This is used to remove the paper jammed in scanning for the ADF.
2	Feed tray of automatic document feeder	This is used to place originals scanned from the ADF.
3	Exit tray of automatic document feeder	Prevent originals scanned from falling off.
4	Cover of scanner	Open the cover of scanner to place the scanned originals on its glass plate.
5	Output Bin	For storing the printed paper.
6	Front USB interface	This is used to scan to an U-disk without a computer.
7	Control Panel	Indicate printer status to conduct set operation.
8	NFC (Near Field Communication) label	Touch this label on mobile device to download or start G&G Print App and connect Wi-Fi Directly.
9	Glass Platen	This is used to place originals scanned from platen.
10	Output Tray	To prevent the printed paper from falling.
11	Front Cover	To open the front cover to take out the laser toner cartridge.
12	Manual feed tray	For placing mediums that are printed in manual feed tray.

13	Power switch	Turn the power on or off and press this button under Ready state to enter energy-saving mode. Press and hold this button for more than 2s to turn the printer power off.
14	Automatic Feeder Tray	For placing mediums that are printed in auto feed tray.
15	Paper deflector of manual feed tray	Slide paper deflector to adapt to paper width
16	Paper width deflector of auto feed tray	Slide paper width deflector to adapt to paper width.
17	Paper length deflector of auto feed tray	Slide paper length deflector to adapt to paper length.
18	Clip of extended tray of auto feed tray	For adjustment of length extension of the tray .

Rear View

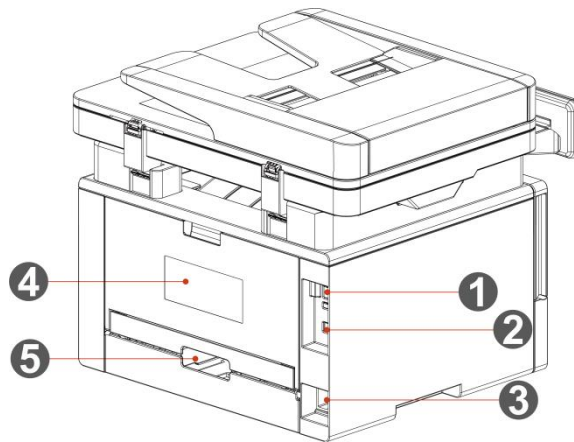

1	Network Interface	For connecting product to network with network cable.
2	USB Interface	For connecting product to computer with USB cable.
3	Power Interface	For connecting product to power with power cord.
4	Rear Cover	For paper release when it gets jammed.
5	Duplex Printing Unit	For paper feed at duplex printing and paper release when paper gets jammed at duplex printing.

Note: • Printer appearance may differ because of various models and functions, so the schematic diagram is only for your reference.

Control Panel

Overview of control panel

The layout of the printer control panel is shown below:

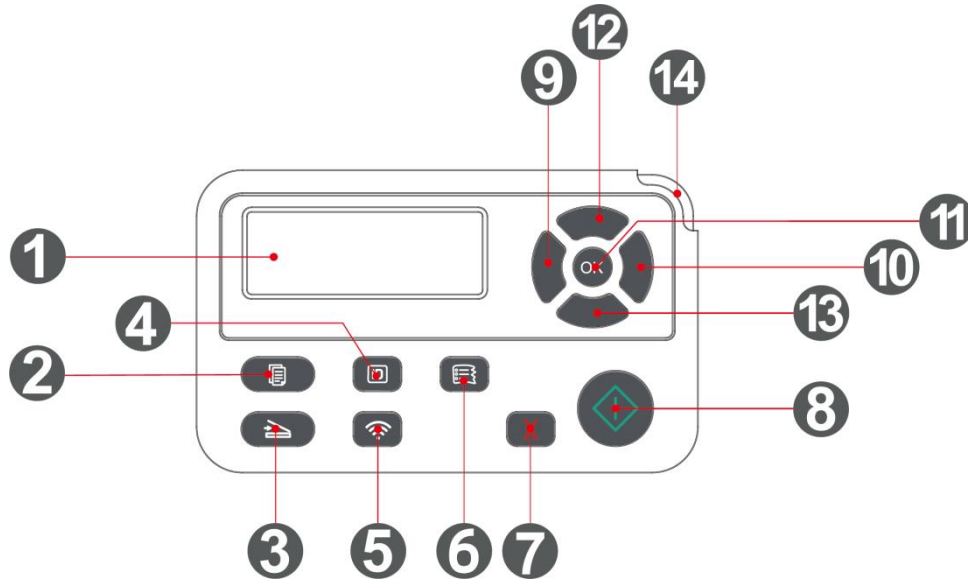

1	LCD Display	Display operation interface and product information.
2	Copy Button	Press this button to enter into copy mode.
3	Scan Button	Press this button to enter into scan mode.
4	ID Card Copy Button	Press this button to enter into ID Card Copy mode.
5	Wi-Fi button	Short press Wi-Fi button to turn on direct Wi-Fi connection of the printer and automatically print out "Mobile Device Wi-Fi Connection Wizard" page (for models with Wi-Fi function only). Long press Wi-Fi button for over 2s to start WPS when Wi-Fi is not connected or to disconnect Wi-Fi when it has already been connected (for models with Wi-Fi function only). Open save toner function(applicable to non-Wi-Fi model only).
6	Bill Copy Button	Press this button to enter into Bill Copy mode.
7	Cancel	Execute cancel operation Idle state interface under copy mode, to reset the "Number of Copies" to 01.
8	Start Button	This is used to start relevant operations after finishing operation settings. In case of a feed failure, please press this key for pick-up and printing again.
9	Menu	Open the main menu of control panel



10	Back	Return to the previous menu.
11	OK	Confirm the selection on screen.
12	UP	Scroll through the menus and options . Increase 1 copy on the ready interface of Copy mode.
13	Down	Scroll through the menus and options . Decrease 1 copy on the ready interface of Copy mode.
14	Status Light	Indicate the status of printer.

Function of status indicator

The meanings of status displayed by the status indicator are as below:

No.	Status displayed by the status indicator	Status	Status Description
1		Die out	Shutdown or sleep state
2		Green indicator normally on	Printer is ready
3		Green indicator blinks	Operative modes of Print, Copy, Scan, others
4		Orange indicator blinks	Low toner warning
5		Red indicator normally on	<ul style="list-style-type: none"> • Toner cartridge error (uninstalled ink cartridge, unmatching ink cartridge, invalid toner cartridge) • Drum unit error (the drum units are not installed, not compatible or come to the end of their service lives.) • Paper error (a paper out, paper jam or feed failure occurs) • Scan error (a scanning failure occurs, and the ADF has an open cover or a paper jam.)

Function of power indicator

No.	Status displayed by power indicator	Status	Status Description
1		Die out	Shutdown status
2		Always on	Booting and ready states
3		Blink	Sleep mode

02 Paper and Print Media

Paper Specification

Automatic Feeder Tray	Media Type	Plain paper(70~105g/m ²),thin paper(60~70g/m ²)
	Media size	A4, Letter, A5, Legal, Statement, JIS B5, Folio, Oficio, Executive, ISO B5, A6, B6, 16K, Big 16K, 32K, Big 32K,Custom
	Media weight	60~105g/m ²
	Maximum capacity of the tray	250 pages (80 g/m ²)
Manual feed tray	Media Type	Plain paper(70~105g/m ²),thin paper(60~70g/m ²),thick paper(105~200g/m ²),transparent film,carton paper,label paper, envelope
	Media size	A4, Letter, Legal, Folio, Oficio, Statement, Executive, JIS B5, ISO B5, A5, A6, B6, Monarch Env, DL Env, C5 Env, NO.10 Env, C6 Env, Japanese Postcard, ZL, 16K, Big 16K, 32K, Big 32K, Yougata4, Postcard, Younaga3, Nagagata3, Yougata2,Custom
	Media weight	60~200 g/m ²
	Maximum capacity of the tray	1 pages

Note: • 80 g/m² standard paper is recommended for this printer.

- It is not recommended to use special paper extensively, which may affect the service life of the printer.
- The print media that does not meet the guidelines listed in this User Guide may result in poor print quality, increased paper jam and excessive wear of the printer.
- Properties such as weight, composition, texture and humidity are important factors affecting the printer performance and output quality.

Loading Paper

Note: • Printer appearance may differ because of various models and functions, so the schematic diagram is only for your reference.

Loading into the Automatic Feeder Tray

1. Slide out the automatic feeder tray from the printer.

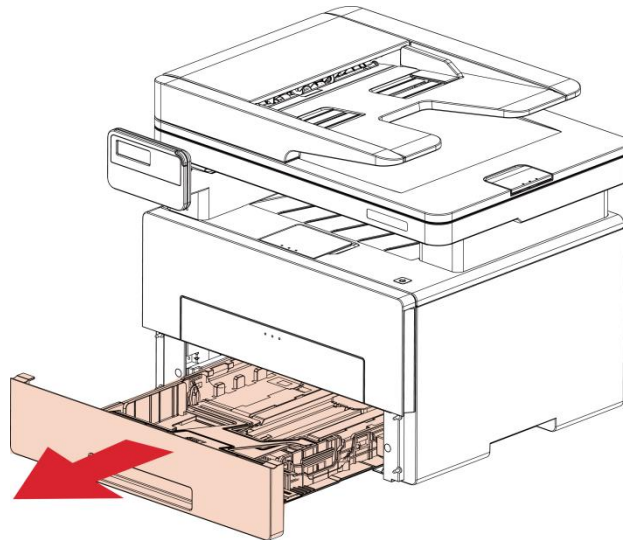

2. Slide the clip of extended tray of auto feed tray, paper length deflector and paper width deflector to the slot suitable for paper size, in order to match paper length and width.

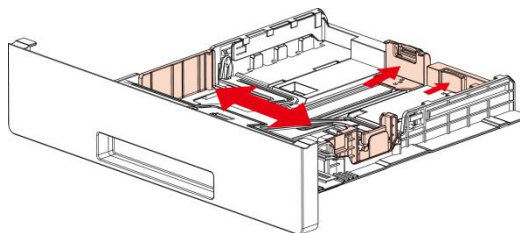

Note: • Do not overly squeeze the "paper length guide" and "paper width guide", otherwise it could easily lead to deformation of paper.

3. Before loading paper, please unfold the stacked paper to avoid a paper jam or feed error, and then load the paper into the tray print-side down. The automatic feeder tray can be loaded up to 250 pages, 80g/m² paper.

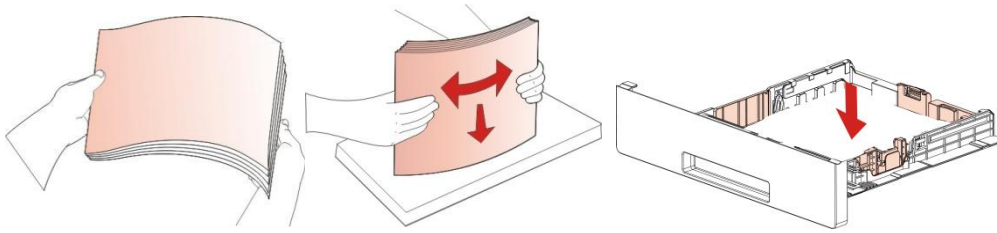

4. Raise the output tray to avoid the printed paper from slipping and falling, or immediately remove the printed document after the printing is complete.

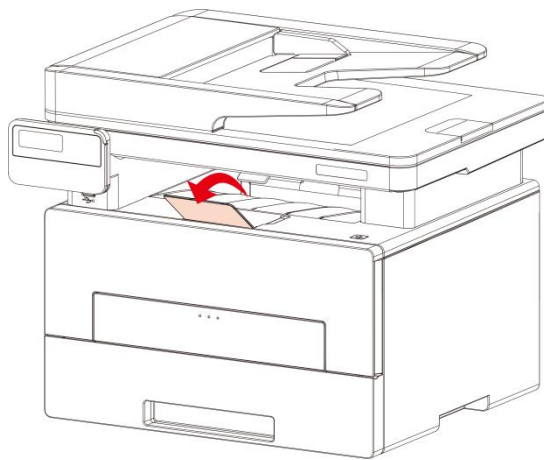

- Note:**
- It is recommended that you raise the output tray to prevent the paper from slipping and falling after printing. If you choose not to raise the output tray, we recommend that you immediately remove the printed paper from the printer.
 - If more than 250 pages (80 g/m²) are put inside the auto feed tray at one time, paper jam or paper feed failure will be led to.
 - If carrying out single-sided printing, please make sure that the side to be printed (the blank side) is face down.

Install manual feed tray

1. Raise the output tray to avoid the printed paper from slipping and falling, or immediately remove the printed document after the printing is complete.

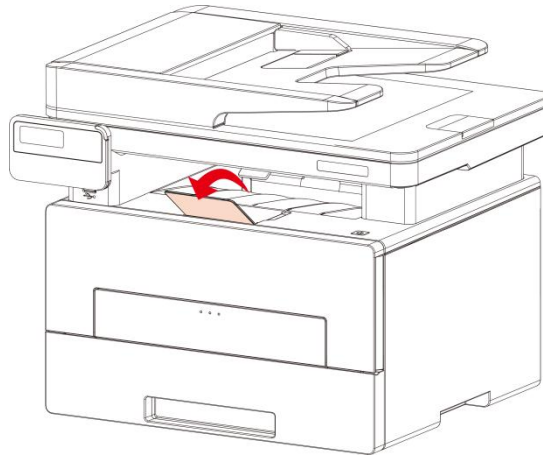

2. Open manual feed tray.

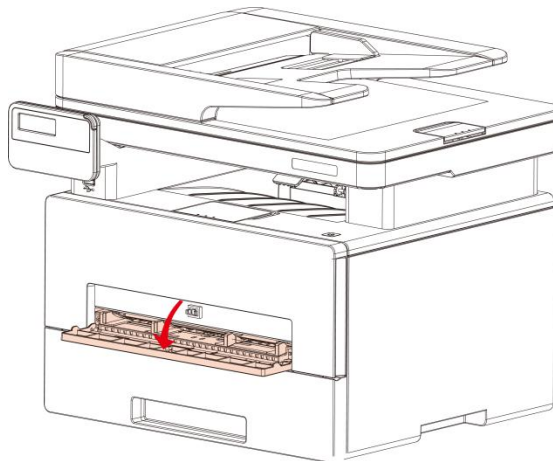

3. Slide the paper deflector of manual feed tray to match the two sides of paper. Do not use excessive force; otherwise, paper will be made jammed or skewed.

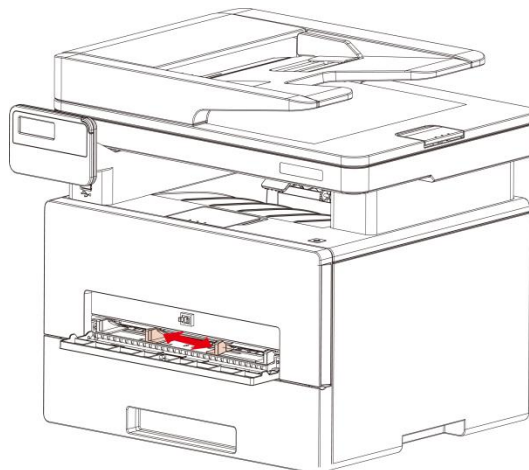

4. Put a flat printing medium into the manual feed tray with both hands.

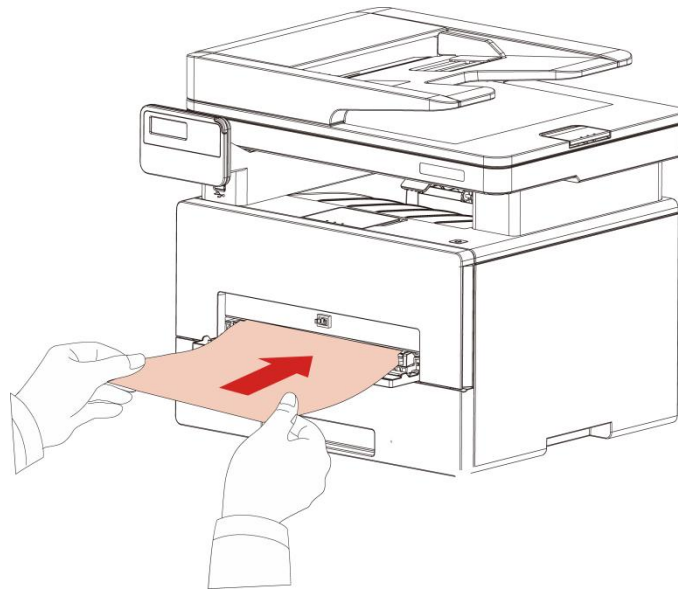

Note: • The printer will enter manual feed mode automatically when you put papers inside the manual feed tray.

• Please put one printing medium inside the manual feed tray each time and put in another piece after finishing printing.

• Put the printing medium inside the manual feed tray with the printing side up; the top of paper should be put inside first.

5. When the printed page is output from the printer, put the second piece inside according to the above steps to continue printing. Slow action will lead to the prompt of paper out or paper failure of manual feed tray. After paper is put inside, printing will be resumed automatically; too quick action may make paper caught up in the printer, which will easily result in paper jam.

Note: • After printing, please take out printed papers output from printer immediately. Stacked papers or envelopes will lead to paper jam or wrapped paper.

Paper and Manuscript Use Process

Manuscript requirements:

Source	Type	Size
Automatic document feeder (ADF)	Plain paper	A4, A5, B5, A6, Letter, Folio, Legal
Platen	Plain paper, thin paper, thick paper, transparent film, carton paper, label paper, envelope	A4, A5, B5, Letter, Full Scanning Platen, Custom

Scanning With Tablet

Note: • Printer appearance may differ because of various models and functions, so the schematic diagram is only for your reference.

Steps of Use:

1. Lift up the scanner cover.

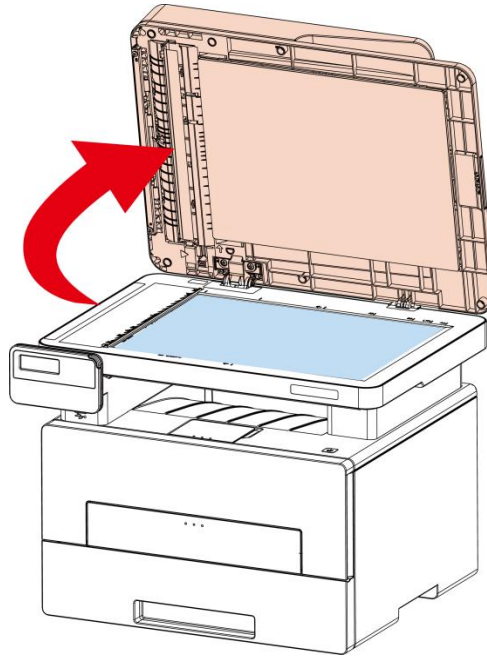

2. Load the manuscript face down.

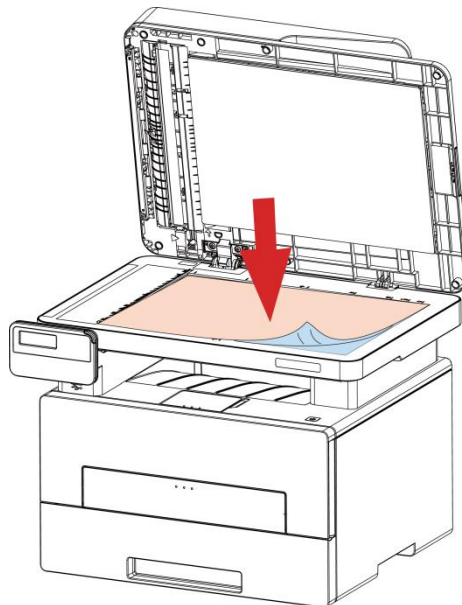

3. Align the manuscript to match the appropriate paper size.

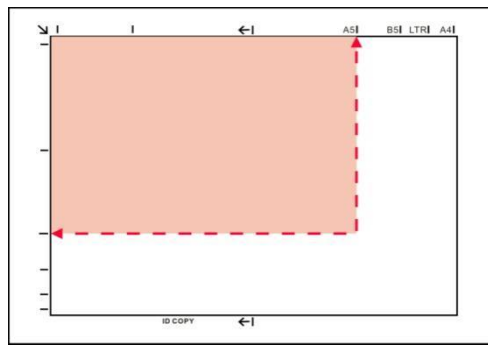

Note: • If the manuscript does not match with any size marker, please align the upper-left corner of the manuscript with the arrow.
• Make sure there is no document in the ADF. If a document is detected in the ADF, it will be more preferential than that on glass platen.

4. Close the scanner cover gently.

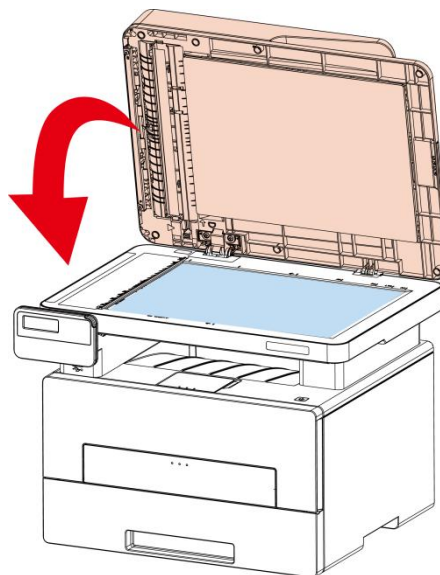

Note: • Please put the paper or document on the scanner glass after the glue, ink or correction fluid are completely dried.
• Rough textured, uneven, oil stained and extremely smooth paper will make printing effect poor.
• Please make sure that there is no dust, fluff, etc. on the paper.
• Paper shall be put on a flat surface and stored under a cool and dry environment.
• To avoid influencing the definition, please don't open the scanner cover during scanning with the platen.

Scan with the automatic document feeder (ADF)

1. Put the original into the ADF with its front upward and top fed first.

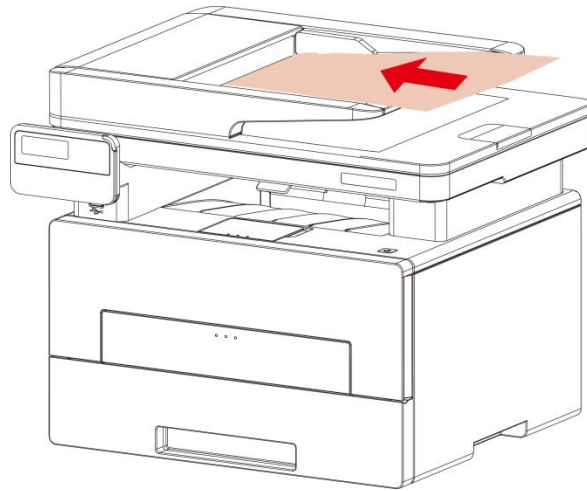

2. Adjust the document guide till it gets close to the paper stack.

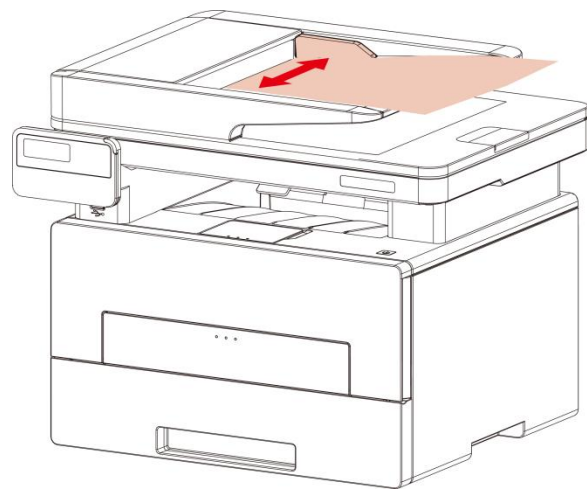

Note: • The ADF supports feeding 50 pieces of paper at most that should be fed one by one.

03 Driver installation and uninstallation

Driver Setup

This software provides a one-click installation method for driver installation on Windows and macOS systems, which can help you automatically complete the driver installation faster and more easily.

Note: • Driver installation interface may differ because of different models and functions, so the schematic diagram is only for your reference.

One-click Installation(For Windows and macOS)

One-click installation provides you with three installation methods: "Wi-Fi", "USB", and "Wired Network". This manual focuses on the "Printer Installation by USB Connection".

Connect printer via USB cable

1. Connect the printer to computer via USB cable, then power the printer on.
2. Insert the accompanying installation disk into the computer CD drive, or log in to G&G official website (www.gg-printer.ru) to download the drive.

Note: • Some computers may be unable to auto play the CD because of system configuration. Please double click "Computer" icon, find "DVD RW driver", then double click "DVD RW driver" to run the installation procedure.

3. Read and agree to the terms contained in the End User License Agreement and the Privacy Policy, click the "Next" button in the lower right corner of the interface to enter the driver installation interface.
4. For Windows, follow Step 5. For macOS, enter PC password before proceeding to Step 5.

5. The setup will start when you click on "One-click installation" under USB. The setup may take a while, depending on your PC configuration. Please wait.

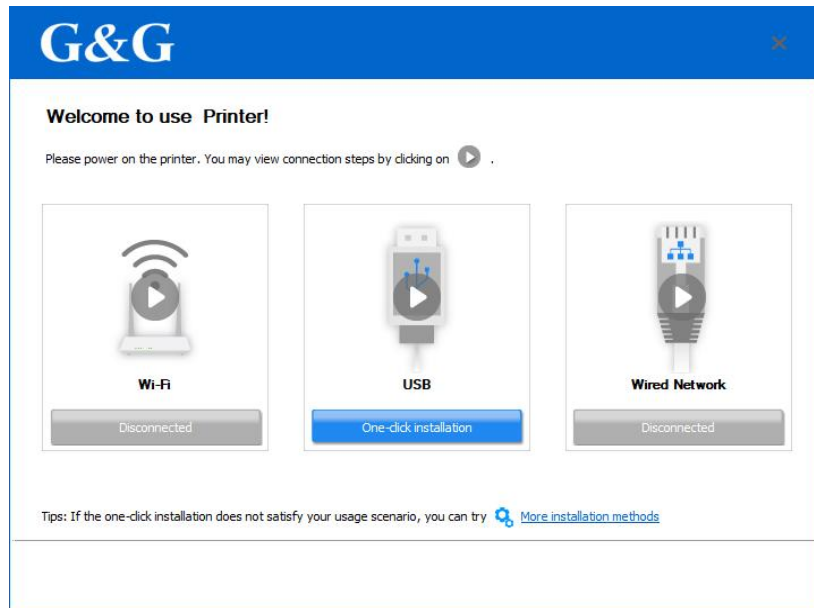

6. After the installation, click "Print & Test Page" button. If your printer prints the test page successfully, it means that you have installed the driver correctly.

Uninstall Driver

Method to uninstall driver under Windows

Windows 10 is taken as the example in the following operation. The information on your computer screen may differ because of multiple operating systems.

1. Click the Start menu of computer and then click All programs.
2. Click "GG IMAGE"
3. Click uninstall to delete the driver according to instructions on uninstall window.
4. Restart computer after finishing unloading.

Method to uninstall driver under macOS

macOS10.14 is taken as the example in the following operation. The information on your computer screen may differ because of multiple operating systems.

1. Click "Go" - "Applications" - "GG IMAGE" - "Utilities" - "GG IMAGE Un-install Tool".
2. Delete the driver as instructed in the pop-up Uninstall window.
3. Uninstall complete.

04 Wired network setup (applicable to wired network models)

In case printers support wired network printing, they can be connected to network to control printer to print in wired network mode.

Set IP Address

The IP address of the printer may be automatically obtained through DHCP function or set manually.

Automatic Setting

DHCP automatic setting function is enabled by default on the printer.

1. Connect the printer to the network through a network cable and complete the startup preparation work.
 2. The printer will receive the IP address assigned by server automatically. It may take server minutes to receive IP address under the influence of network environment.
- You can check the IP address of printer by printing "Network setup page" out or check network information by viewing the control panel of printer. If the IP address is not listed, please check network environment and then try again after waiting for several minutes.

Note: • If DHCP server fails to assign IP address automatically, the printer will get the link-local address assigned by printer automatically: 169.254.xxx.xxx.

Manual Setting

To set up IP address for printer through the control panel of printer manually.

To set up IP address for printer through the embedded Web server manually.

05 Wireless network setup (applicable to Wi-Fi models)

Wireless network connection type is divided into basic structure mode and Wi-Fi Direct mode. If you have problems with wireless network setup, please refer to Wireless Network Setup FAQs.

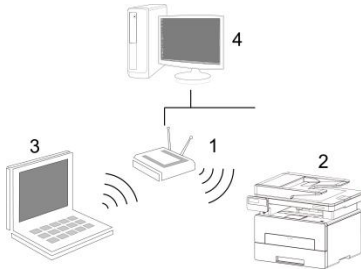

Basic structure mode: connecting to a wireless device via router

1. Access point (wireless router)
 2. Wireless network printer
 3. Computer connecting to access point via wireless network
 4. Computer connecting to access point via network cable
-

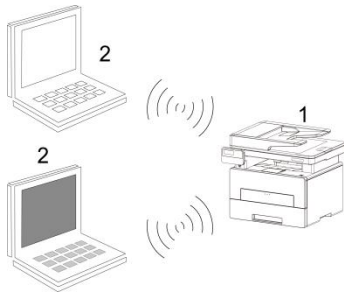

Wi-Fi Direct mode: wireless client is connecting to a printer with Wi-Fi function

1. Wireless network printer
 2. Wireless client is directly connecting to a wireless network printer
-

Basic structure mode

You can connect a computer to your printer via access point (wireless router) as the medium. Access point (wireless router) connection is divided into wireless network setup and Wi-Fi Protected Setup (WPS).

Important: Before wireless network installation, you must learn about the service set identifier (SSID) and password of your access point in order to use them during wireless network setup. If they cannot be determined, please consult your network administrator or access point (wireless router) manufacturer.

Wireless network setup tools

If your computer has been installed with a driver and had been connected to wireless network, but the wireless network was changed, you can set it again with wireless network setup tools.

Preliminary preparations

1. Access point (wireless router).
2. A computer that has been connected to network.
3. A printer that has wireless network function.

Setup methods of wireless network setup tools

Take the wireless network setup tool in computer.

1) Windows system: Click the "Start menu" – "All programs" - "GG IMAGE" – Product name – "Wireless network setup tool".

2) macOS system: click "Go" - "Applications" - " GG IMAGE " - "Utilities" - "GMxxx" - "Wireless Network Configuration Tool" on the computer Finder menu bar.

How to disable the Wi-Fi network connected

Connect the wireless network in infrastructure mode by the steps above. If connected, the Wi-Fi light on the control panel is normally on. Press and hold this button for more than 2s to disconnect from Wi-Fi network (Wi-Fi light will be off).

06 Web server

You can manage printer setup via the embedded Web server.

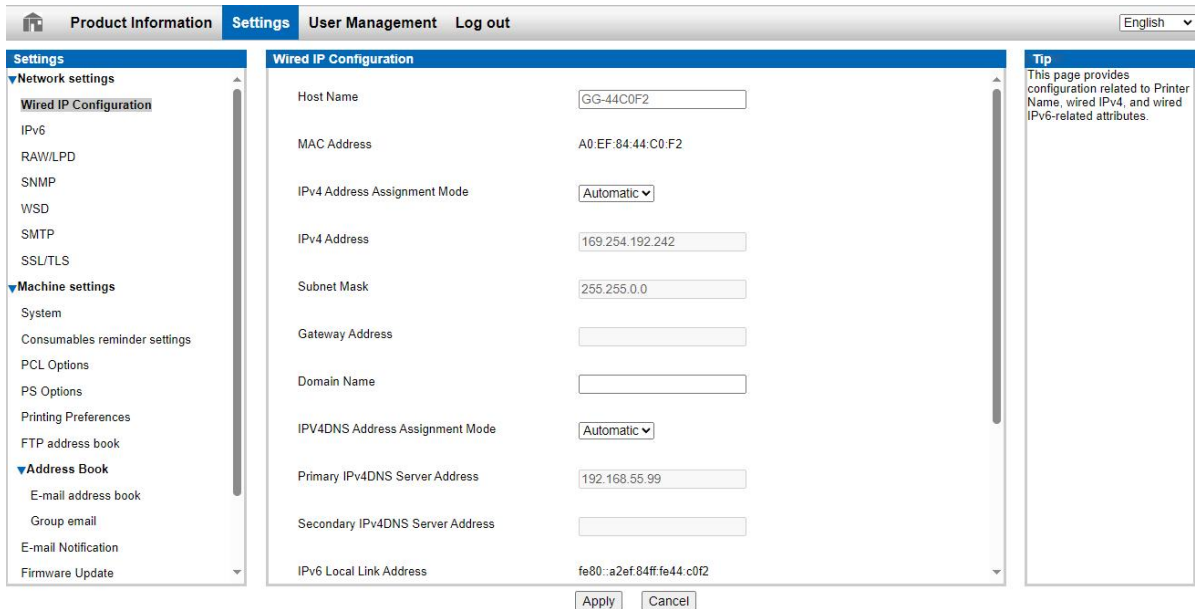

Visit the embedded Web server







1. Turn on the power of printer and computer.
2. Connect the printer to network to ensure that the printer is connected to the network where the computer is connected to.
3. Input the IP address of printer in the address bar of Web browser to visit the Web server imbedded in printer.
4. Click "Log in" option, input user name and password (the default user name is admin and the initial password is 000000) and click "Log in".

Note: • For safety reasons, you are suggested to change the default password, which can be finished in the "User Management" interface.

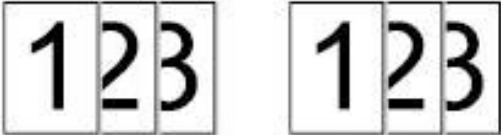
07 Print

Print Function

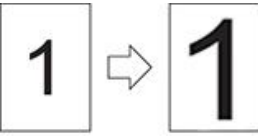
You can set the print function through "Start"->"Devices and Printers"- select corresponding printer- right click – set print function in "Printing preferences". Some functions are as follows:

Functions	Diagram
Automatic Two-Sided Printing	
Collate Print	
Reverse Print	
N-in-1	
Poster Print(for Windows Operation System only)	
Zoom Print	
Custom Size	

- Note:** • You can realize poster printing feature by selecting 2x2 poster printing in multipage.
 • You can enable printing preference and click the help button to view detailed function description.

Print Settings

Setting the printing parameters

You can set up printing parameters with the following two methods before sending printing work (such as paper type, paper size and paper source).

Operating system	Temporary printing setup change	Permanent default setup change
Windows	1. Click "File" menu – "Print" – "Select printer" - "Printer properties" (the detailed steps may differ because of multiple operating systems).	1. Click "Start" menu- "Control Panel" – "Devices and Printers". 2. Right click on the printer icon, select "Printing preference" and then change setup and save it.
macOS	1. Click "File" menu – "Print". 2. Change setup in the window popping out.	1. Click "File" menu – "Print". 2. Change setup in the window popping out and click to save the preset. (Select preset every time before printing, or print according to default setup.)

- Note:** • Priority of App setup is senior to printer setup.

Automatic Two-Sided Printing

The printer supports automatic two-sided printing of plain paper. Paper size supported by the automatic two-sided printing: A4,Letter, Legal, Oficio, Folio.

- Note:** • Trying the automatic two-sided printing may damage the printer if some paper media are not suitable for automatic two-sided printing.
 • Auto duplex printing does not support poster printing.
 • Please refer to [Chapter 2](#) for paper loading and type of mediums that can be printed via auto feed tray.

Duplex printing unit setup

For the purpose of achieving the best printing result, you can set up the paper size of duplex printing unit. As for duplex printing of A4 papers, the slide should be adjusted to the A4 position; as for Letter, Legal, Folio and Oficio duplex printing, the slide should be adjusted to the Letter position.

Setup steps of duplex unit are:

1. Draw out duplex unit.

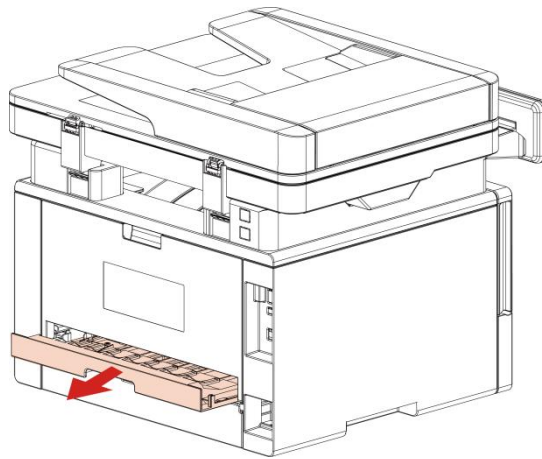

2. Make the backside of duplex unit up.

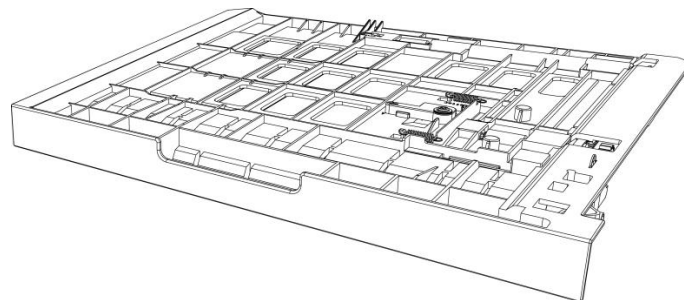

3. Adjust paper size slide to A4 or Letter position to finish setting up.

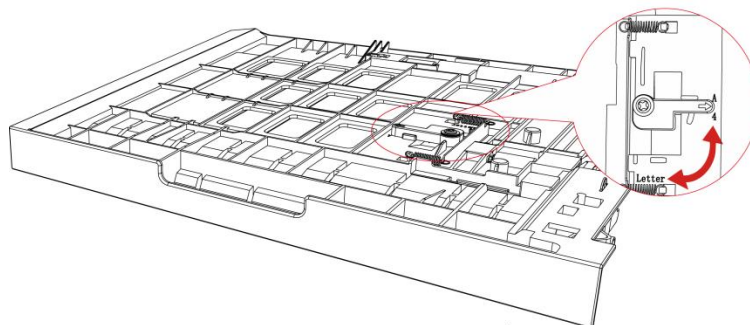

4. Install the duplex unit in the printer.

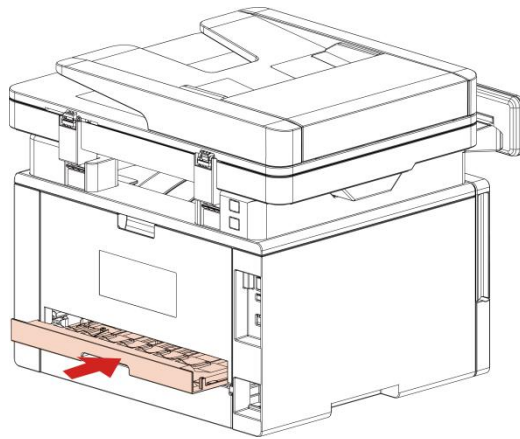

How to carry out auto duplex printing

1. Open the print job to be printed from the application (such as a Notepad).
2. Select Print from the File menu.
3. Select printer of the corresponding model.
4. Single click "Preferences" for printing setup.
5. Select the "Duplex" in "Basic" tab and then select "Long Edge" or "Short Edge".
6. Single click "OK" to finish printing setup. Click "Print" to realize auto duplex printing.

Mute printing

If the Mute Printing is set, the printing noise will be reduced but the printing will slow down to some extent.

The operating steps of mute printing are as follows (applicable to printers that are installed via USB connection)

Windows 10 is taken as the example in the following operation. The information on your computer screen may differ because of multiple operating systems.

1. Enter the "Start menu" – "Control Panel" –view "Devices and Printers".
2. Right click printer and select "Printer properties" in the pull-down menu.
3. Enter the "Secondary Settings" option.
4. Tick "Mute printing" and click "Ok" to finish setup.

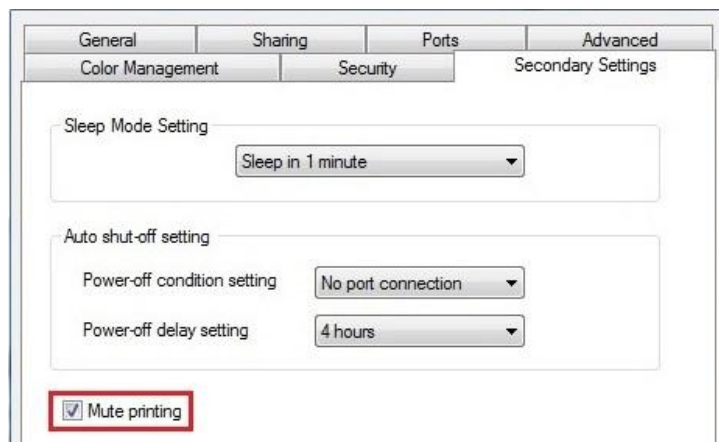

5. Open the printing work from the App, select a printer of the corresponding model and then set up printing according to needs.
6. Click "Print" to realize mute printing.

Note: • Printers with LCD control panel can be set to mute printing with keys on control panel directly.

08 Copying

Copying function

Copy		Instructions
Common copying	Image quality	Set the definition mode to improve the copying effect.
	Intensity	Adjust deep-light copying effect by setting intensity.
	Resizing	Reduce or enlarge the size of image copied.
	Multipage	Print a multi-page document to a piece of paper.
	Clone	Print several identical images to a piece of paper.
	Poster	Print a one-page original to pieces of paper.
	Collated copy	Collate copies of an original.
	Duplex copying	It supports manual duplex copying for originals.
	Paper setting	Set the paper size and paper type.
ID card copying	Arrangement mode	Set the arrangement mode of ID card to be copied.
Receipt copying	Intensity	Adjust deep-light copying effect by setting intensity.
	Paper Size	Set the paper size.
Receipt copying	Paper Size	Set the paper size.
	Multipage	Print a multi-page document to a piece of paper.

Common copying setting

Change related setting through setting menu for better copy result.

1. Press "Copy" and then "Menu" on control panel to enter the "Menu Setting" interface.
2. Press "OK" to enter the "Copy Setting" interface.
3. Press "direction key to select option to be set and press "OK key" to set option.

Note: • The image quality, intensity, resizing and paper setting can keep valid after options are set.
• Settings on all-in-one, clone, poster, collated copy and duplex copy will be restored to defaults after completing the copying, switching among panel keys or rebooting the machine.

Multipage

With setting on all-in-one feature, a 2- or 4-page document could be copied to one piece of paper. Copying with the ADF and the glass platen are both supported.

The multipage includes 3 modes:

(1) Two-in-one:

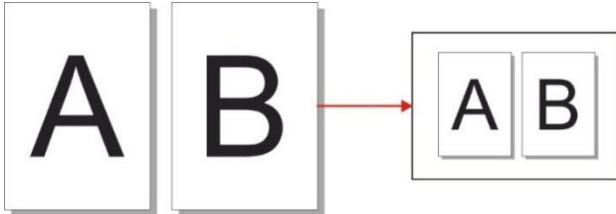

(2) Horizontal four-in-one:

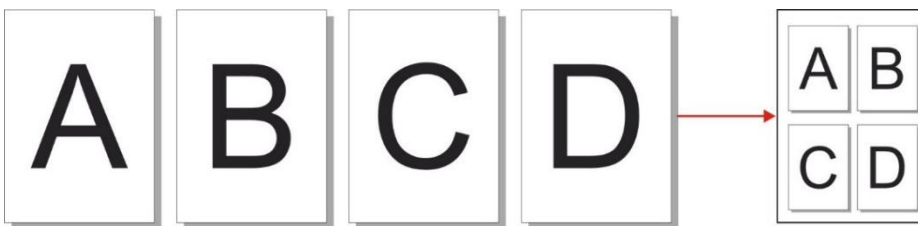

(3) vertical four-in-one:

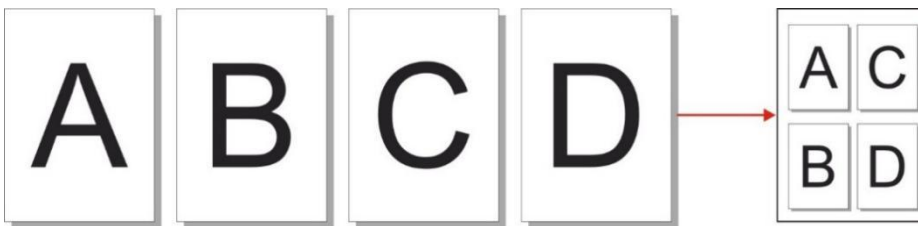

Note: • "Multipage" and "resizing function" cannot be set at the same time.

Collated copy

The "Collated Copies" feature supports only copying with the automatic document feeder (ADF). The collated copy includes 2 modes:

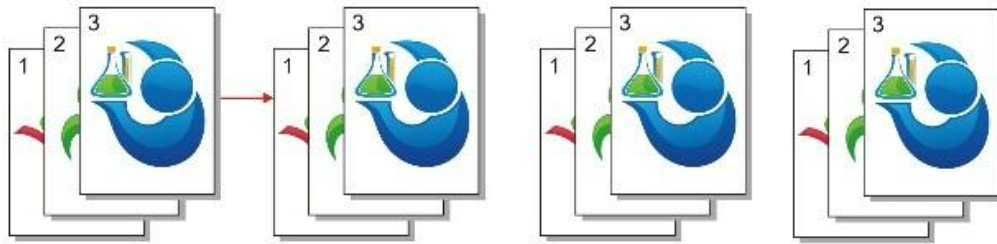

Startup:

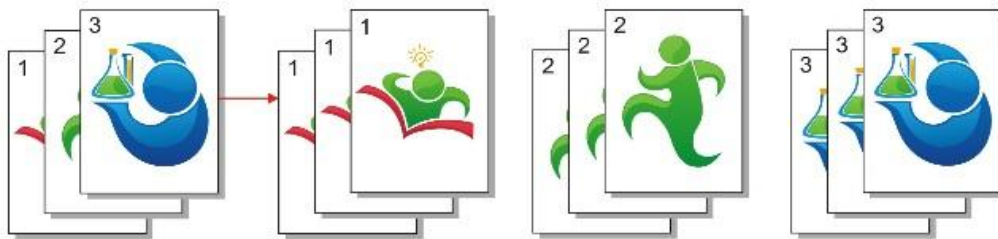

Closed:

Manual duplex copying

You may use the glass platen or the ADF for duplex copying. The followings are examples of copying with the ADF.

There are 4 modes in total for duplex copying:

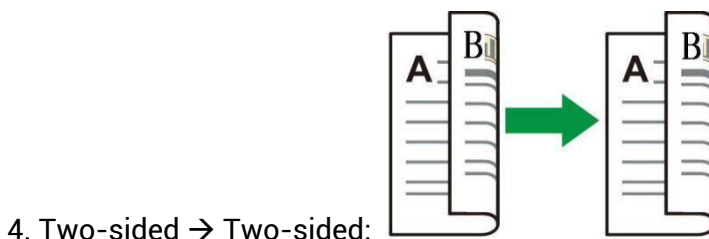
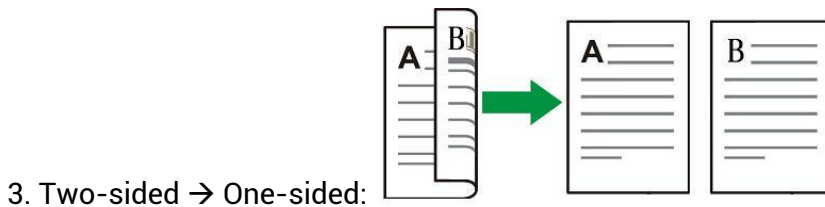
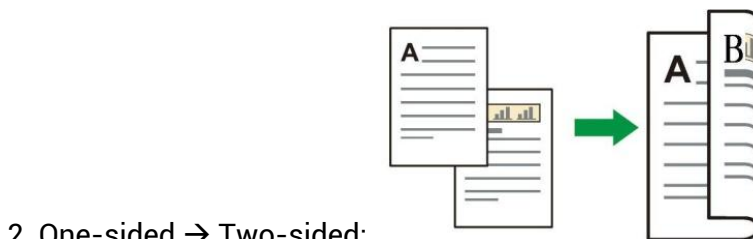
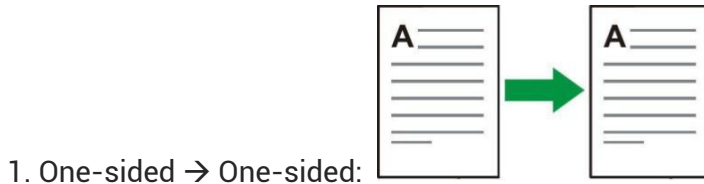

Steps of duplex original copying

1. Put an original into the ADF with its front upward and its top fed first; meanwhile, make sure there are some paper in the carton.

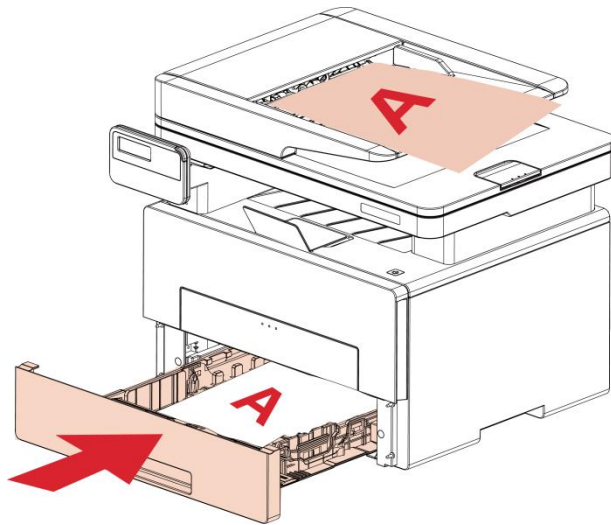

2. Select Duplex Copying and then press "OK" to save settings.
3. Press "Start" to begin copying.
4. Paper exited should be with the direction as shown in the figure:

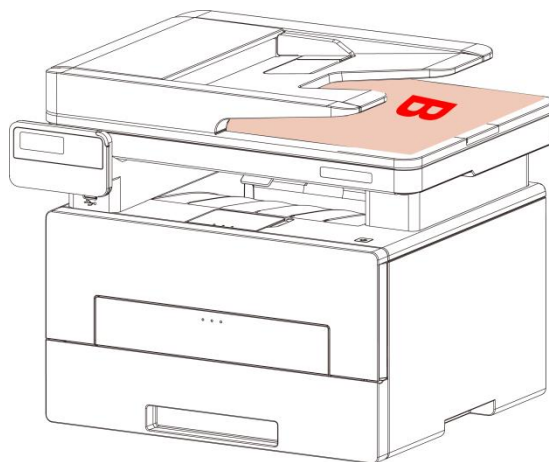

5. After completion of copying one side, put the paper into the entrance as shown in figure (without turnover or rotation).

Note: • If the turnover prompt on panel times out, the machine will execute one-sided copying automatically.

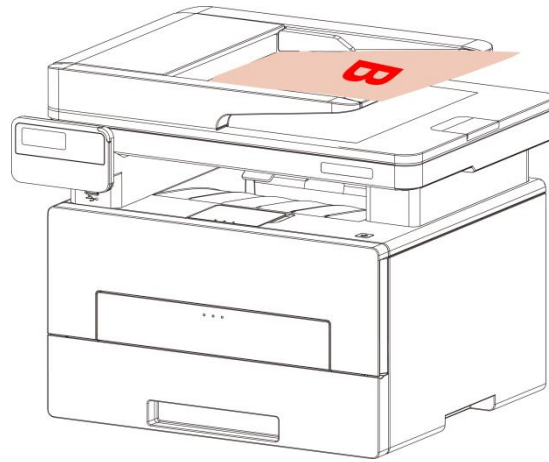

6. Press "Start" to begin copying the other side.

ID card copying setting

Change related setting through setting menu for better copy result.

1. Press "ID Card Copy" and then "Menu" on control panel to enter the "Menu Settings" interface.
2. Press "OK" to enter the "ID Card Copy Settings" interface.
3. Press "direction key" to select option to be set and press "OK key" to set option.

Receipt setting

Change related setting through setting menu for better copy result.

1. Press "Bill Copy" and then "Menu" on control panel to enter the "Menu Settings" interface.
2. Press "OK" to enter the "Bill Copy Setting" interface.
3. Press "direction key" to select option to be set and press "OK key" to set option.

09 Scan

This printer provides two types of scan: "Push Scan", which means scanning through the printer's Control Panel operations; "Pull Scan" which means scanning through PC terminal scanning the application. Before scanning, please be sure a printer driver has been installed in the computer. This product complies with the TWAIN and Windows Image Application (WIA) standard. If using the application which supports TWAIN and WIA standard, users can use the scan function and directly scan the images to the open application.

Pull Scan

You can scan from the PC scan application via USB, wired, or wireless connection. Make sure the printer is properly connected before scanning.

G&G Scan Application

Operation Steps:

1. Double click on " G&G Scan Application" on the computer.
2. The prompt window is shown as below:

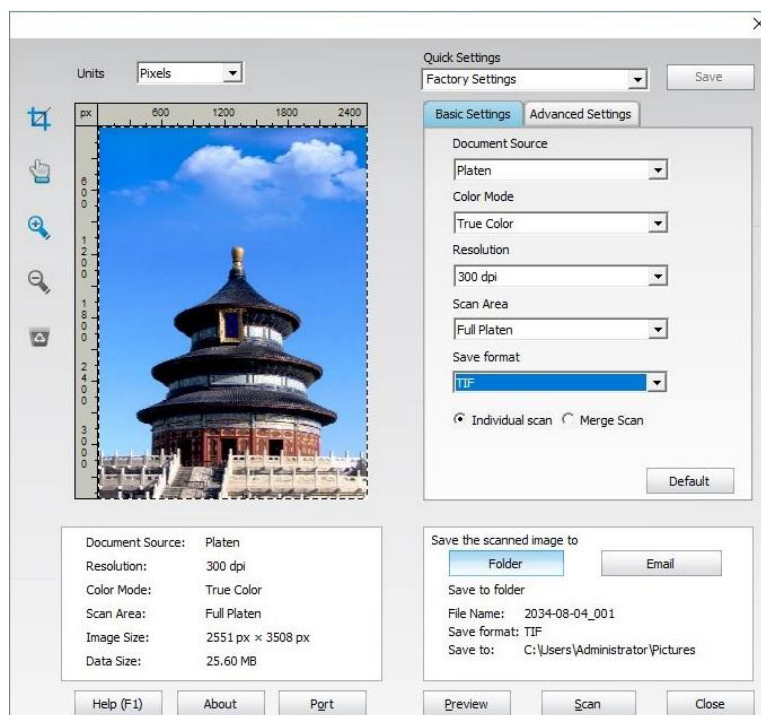

3. Set Scan in the right list. Click "Scan" on the bottom right corner and start scan.

macOS System Scan

ICA Scan

Open ICA via "Print and Scan"

Operation Steps:

1. After installing the printer driver, click "System Preferences" icon on the bottom left corner of the computer desktop.
2. After the window pops up, click on "Print and Scan".
3. After the window pops up, click on "Scan"
4. Click on "Open Scanner" and the scan window will pop up.
5. Click on "Show Details" on the bottom right corner to set the scan parameters.
6. Click on "Scan" on the bottom right corner and start scan.

Call ICA through applications

Operation Steps:

1. Click on "Finder" icon on the bottom left corner of the computer desktop, Find "Image Capture" in "Applications", and click to launch the application.
2. After selecting the printer in the left list, set the scan parameters in the right list. Click on "Scan" on the bottom right corner and start scan.

TWAIN Scan

Take Photoshop as an example. (CS2 and earlier versions are supported)

Operation Steps:

1. Launch Photoshop, click on "File" – "Import" on the top left corner and select TWAIN Scan, as is shown below:
2. After the window pops up, please refer to Step 4 of to see the specific operation steps.

Push Scan

This section is mainly to introduce how to scan files to PC, E-mail, FTP and USB with the printer's control panel.

- Note:**
- The one-page file scanned to PC, E-mail or FTP could be saved in PDF, TIFF or JPEG, OFD; if scanned to USB, it could be saved in PDF and JPEG. OFD.
 - Under merge scan mode, a file scanned to PC or USB will be saved in PDF be default; if scanned to E-mail or FTP, it will be saved in PDF, TIFF or JPEG, OFD.

Scan to PC

You may operate the printer's control panel to scan a file to PC. (Only support connection method of USB connection line.)

1. Be sure the printer and the computer are both switched on and connected with each other properly.
2. Put an original on the glass platen or into the ADF.
3. Press "Scan" and then "▲" or "▼" on control panel to select "One-page Scan" or "Merge Scan"; then, press OK.
4. Press "Menu" and then "OK" to enter the "Scan Setting" interface.
5. Press "▲" or "▼" to select "Scan To" options; then, press OK.
6. Press "▲" or "▼" to select "Scan to PC" and then press OK; press "Start" to begin scanning.
7. For merge scan, please put files to be scanned on the glass platen and then press "Start" to scan the next page (directly continuous scanning is available if scanning with the ADF).

Scan to E-mail

You may scan a black-white or color file as an appendix to the e-mail application, with specific operation steps as follow:

1. Be sure the printer and the computer are both switched on and connected with each other properly.
 2. Please see to configure the SMTP Client.
 3. Please see to configure the e-mail address book.
 4. Put an original on the glass platen or into the ADF.
 5. Press "Scan" button on the control panel, and press "▲" or "▼" to select "Single Page Scan" or "Merge Scan", then press "OK" button.
 6. Press "Menu" and then "OK" to enter the "Scan Setting" interface.
 7. Press "▲" or "▼" to select "Scan To" options; then, press OK.
 8. Press "▲" or "▼" to select "Scan to E-mail" and press "OK" button.
 9. Press "▲" or "▼" to select "E-mail Address Book" or "Group Mail" and press "OK" button.
 10. Press "▲" or "▼" to select address or group and then press "OK" button; press "Start" button to start scan.
 11. For merge scan, please put files to be scanned on the glass platen and then press "Start" to scan the next page (directly continuous scanning is available if scanning with the ADF).
- Please follow these instructions on the settings for group emails:
Set the group name for group e-mail sending by webpage, and set the members, i.e.the receivers, in the group of group email. After finishing scanning, firmware will send the scanned documents to the mail server. Then mail server sends the documents to every member of the group.

Scan to FTP

Be sure the user is in an Internet-connected environment in scanning files to FTP server. If you want to scan large files, you may need to input the server address, user name and password to log in the server, with specific operation steps as below:

1. Be sure the printer and the computer are both switched on and connected with each other properly.
2. Please see to configure the FTP address book.
3. Put an original on the glass platen or into the ADF.
4. Press "Scan" button on the control panel, and press "▲" or "▼" to select "Single Page Scan" or "Merge Scan", then press "OK" button.
5. Press "Menu" and then "OK" to enter the "Scan Setting" interface.
6. Press "▲" or "▼" to select "Scan To" options; then, press OK.
7. Press "▲" or "▼" to select "Scan to FTP" and press "OK" button.
8. Press "▲" or "▼" to select the server and press "OK" button; Press "Start" button to start scan.
9. For merge scan, please put files to be scanned on the glass platen and then press "Start" to scan the next page (directly continuous scanning is available if scanning with the ADF).

Scan to U disk

This printer supports scanning files to USB without a computer. Before operation, please make sure the USB has enough storage space. The specific operation steps are as follow:

1. Insert the USB into the printer's front USB interface.
2. Put an original on the glass platen or into the ADF.
3. Press "Scan" button on the control panel, and press "▲" or "▼" to select "Single Page Scan" or "Merge Scan", then press "OK" button.
4. Press "Menu" and then "OK" to enter the "Scan Setting" interface.
5. Press "▲" or "▼" to select "Scan To" options; then, press OK.
6. Press "▲" or "▼" to select "Scan to USB" and then press "OK"; press "Start" to begin scanning.
7. For merge scan, please put files to be scanned on the glass platen and then press "Start" to scan the next page (directly continuous scanning is available if scanning with the ADF).

The printer will create a folder named GGIMAGEScan in which all scanned files are saved in PDF or JPG.

Note: • USB formats supported: FAT and FAT32 for Windows system and MS-DOS (FAT) for macOS system.

10 Routine Maintenance

Note: • Printer appearance may differ because of various models and functions, so the schematic diagram is only for your reference.

Cleaning the Printer

Note: • Please use mild detergents.

• Some parts of the printer are still in high temperature within a short time after use. To prevent burns, please don't directly touch places labeled with high temperature warning in contact with internal components after opening the printer's front or rear cover.

1. Use a soft cloth to wipe the outside of the printer clean.

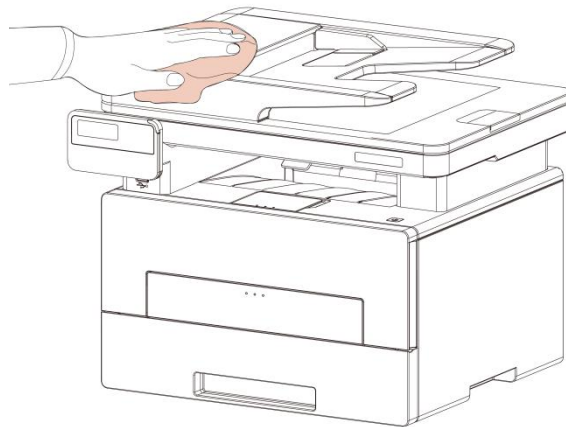

2. Open the scanner cover and then wipe the glass platen gently with a soft cloth.

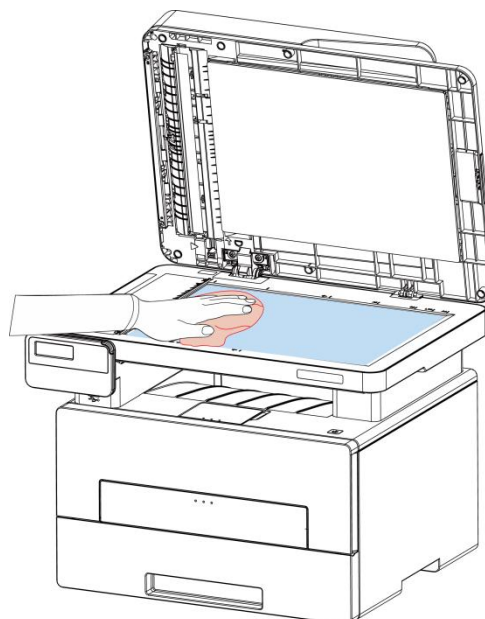

3. Open the front cover and take the laser toner cartridge out along the track.

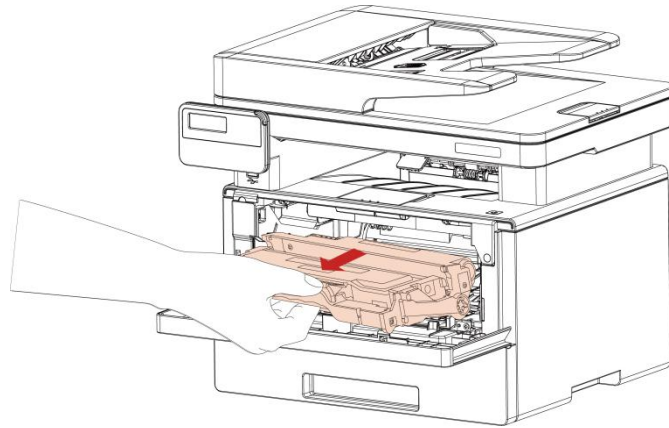

Note: • When removing the toner cartridge, put the toner cartridge in a protective bag or wrap it with thick paper to avoid direct light damaging the toner cartridge.

4. Clean the inside of the printer by gently wiping the shaded area, as shown in picture, with a dry and lint-free cloth.

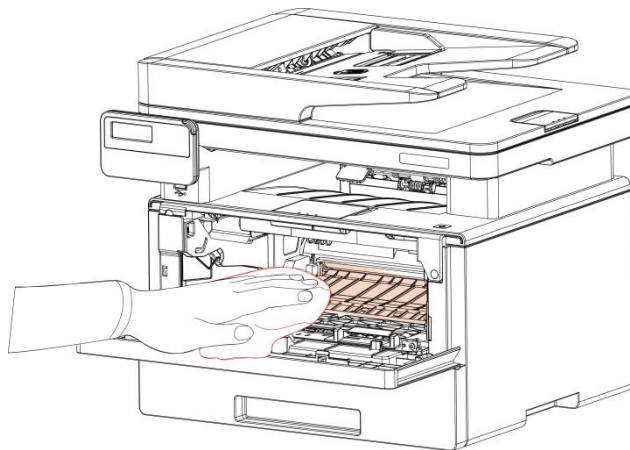

5. Wipe the LSU lens of printer gently with dry lint cloth.

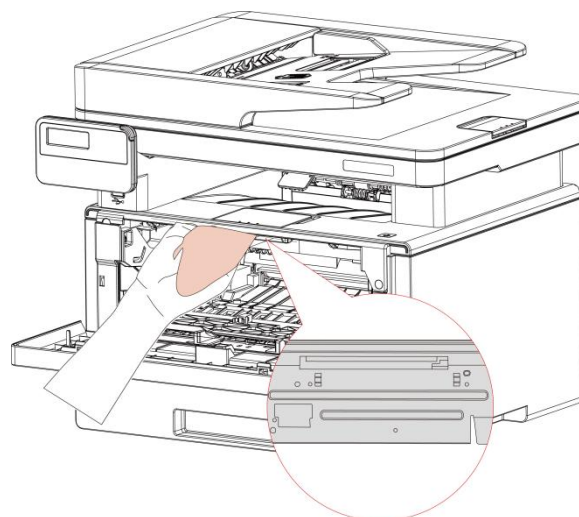

6. Open the auto feed tray and wipe the pickup roller gently with dry lint cloth.

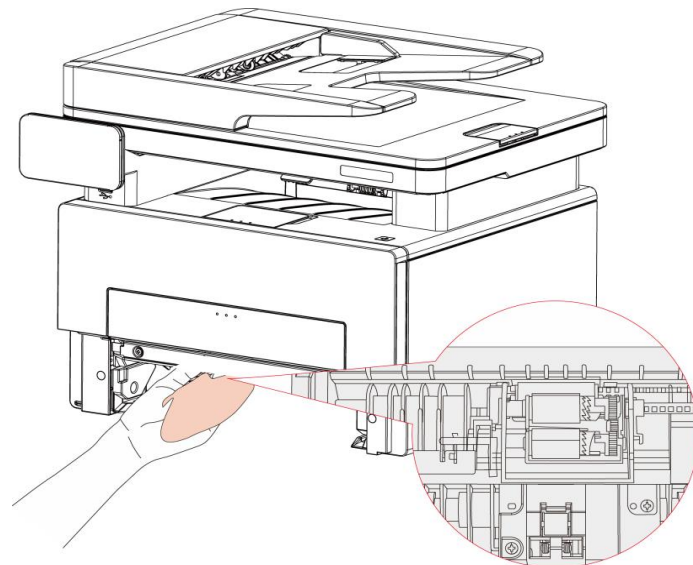

Note: • The machine with the ADF should be regularly cleaned, removing dirt on the top cover of the ADF. Please wipe the place as shown in figure with a soft cloth.

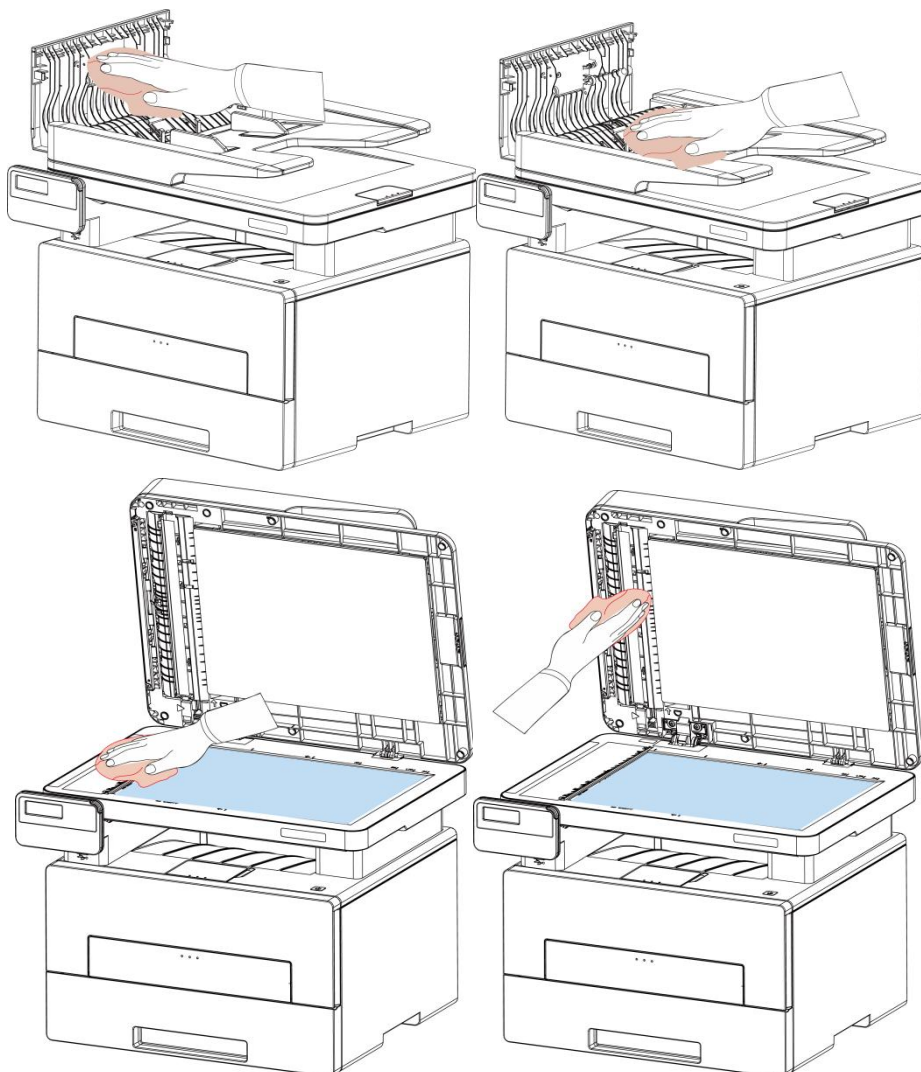

Toner cartridge and drum component maintenance

About toner cartridge and drum component component

1. Cartridge, use and maintenance of the drum assembly.

Please use the original toner cartridge for better printing quality.

Please pay attention to the following items while using the toner cartridge:

- Please keep the toner cartridge in a dry and dark place.
- Do not refill the toner cartridge without permission; otherwise, the damages caused will not be included in the scope of warranty of the printer.
- Please place the toner cartridge in cool and dry places.
- Please do not place the toner cartridge near ignition sources, as the toner inside it is inflammable and may cause fire.
- Please pay attention to toner leakage while it is taking out or disassembled. In case of toner leakage, skin contact with toner or spattering into eyes or mouth, please wash it with clear water immediately, or see a doctor if feeling unwell.
- When placing the cartridge, please stay away from children may contact area.

2. Service life of toner cartridge

- The service life of toner cartridge is depending on the toner quantity needed by printing.
- When a prompt that "The Toner Cartridge life Expired" appears on the display, it indicates its service life expires. So please replace it.

3. Service life of drum component

- When a prompt that "The Drum Unit life Expired" appears on the display, it indicates its service life expires. So please replace it.

Replace toner cartridge and drum component

Note: • Please pay attention to the following matters before replacing toner cartridge:

- Since there may be toner on the surface of toner cartridge, please pay attention while taking it out to avoid spattering.
- Please place the toner cartridge taken out on paper to avoid large-scale spattering of toner.
- When installing, do not touch the surface of the toner cartridge, so as to avoid scratching it.

Toner cartridge replacement steps:

1. Power off the printer.

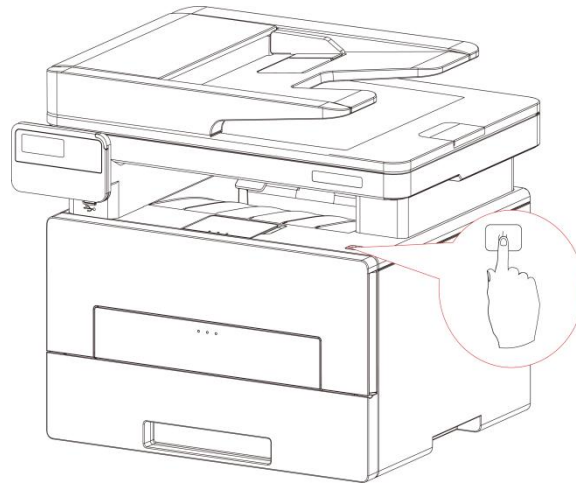

2. Open the front cover and then remove the laser toner cartridge along the guide rail.

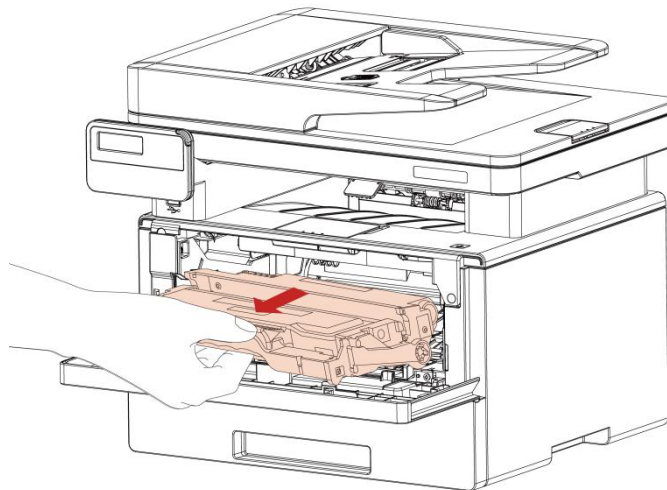

3. Press the blue button on the left side of drum component with left hand and lift the toner cartridge handle with right hand at the same time to take the toner cartridge out.

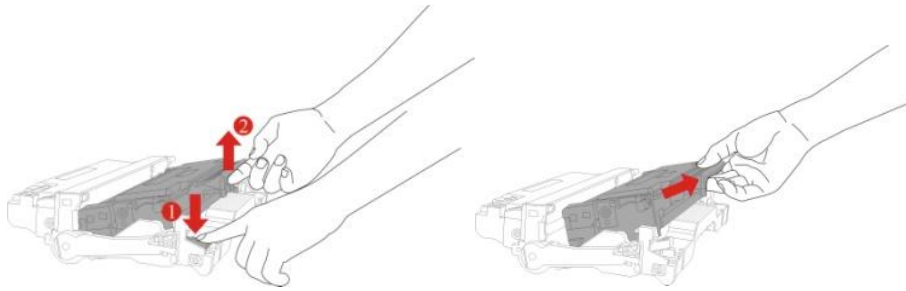

4. Open the package of the new toner cartridge and hold the toner cartridge handle to shake it left and right for 5 – 6 times, so that the toner inside can be uniformly dispersed.

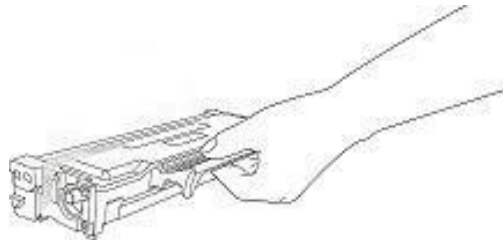

5. Pull the seal out and take the toner protection cover out.

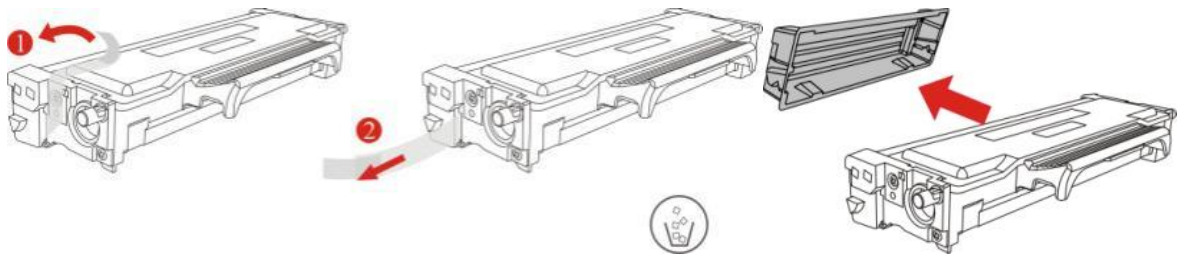

6. Install the drum component along the inner track to finish installing toner cartridge.

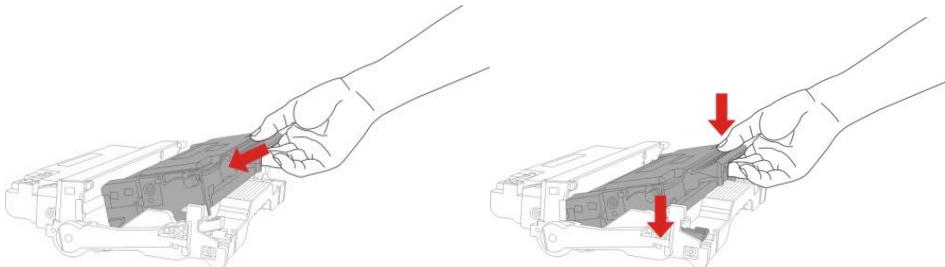

7. Take the drum component with toner cartridge installed and install it inside the printer along the inner track of printer to finish installing.

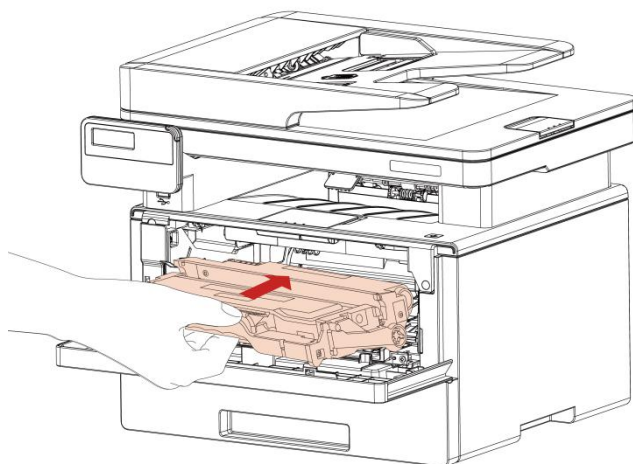

8. Close the front cover.

Replace the drum assembly steps are as follows:

1. Power off the printer.

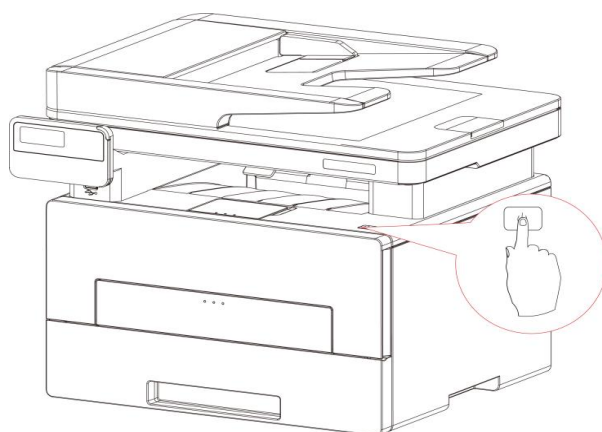

2. Open the front cover and take the laser toner cartridge out along the track.

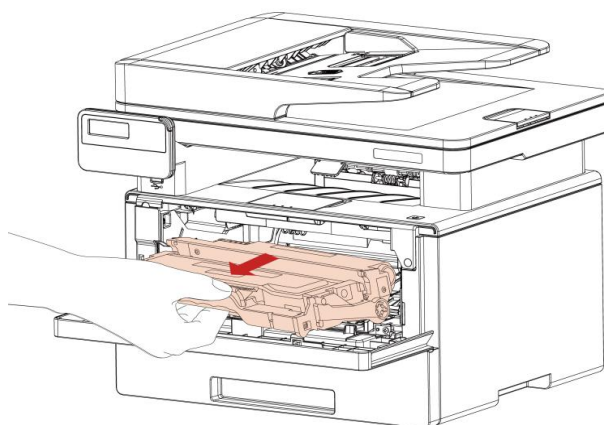

3. Press the blue button on the left side of drum component with left hand and lift the toner cartridge handle with right hand at the same time to take the toner cartridge out.

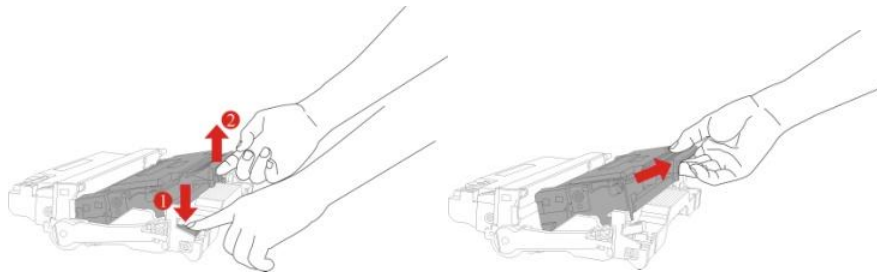

4. Open the package of new drum component, take the protection device of drum component, and put the drum component on a horizontal table.

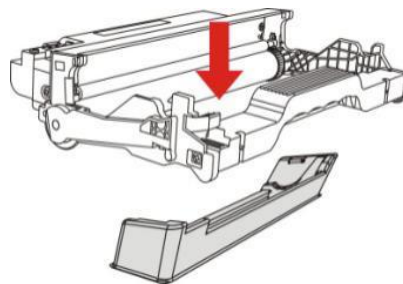

5. Install the drum component along the inner track to finish installing toner cartridge.

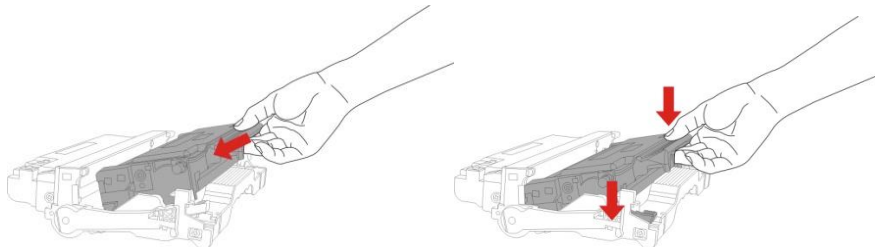

6. Take the drum component with toner cartridge installed and install it inside the printer along the inner track of printer to finish installing.

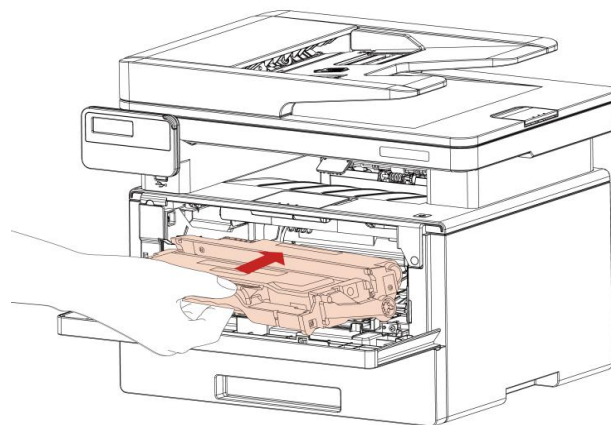

7. Close the front cover.

11 Troubleshooting

Please read this section carefully. It may help you to solve common problems encountered during the printing process. If the problems persist, please contact G&G Aftersales Service Centre.

Prior to handling common problems, first check that:

- The power cord is connected correctly and the printer is powered on.
- All of the protective parts are removed.
- The toner cartridge is installed correctly.
- The paper is correctly loaded into the tray.
- The interface cable between the printer and the computer is connected correctly.
- The correct printer driver has been selected and installed properly.
- The computer port is properly configured and is connected to the correct printer port.

Cleaning Jammed Paper

Middle jam

Note: • When removing the paper jam, please don't touch immediately places labled with high temperature warning in contact with internal components after opening the printer's front or rear cover, to prevent burns.

1. Pull paper tray out.

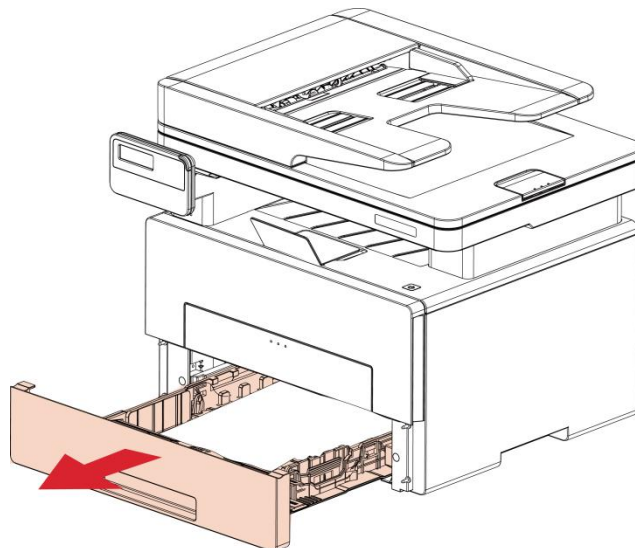

2. Gently pull the jammed paper out.

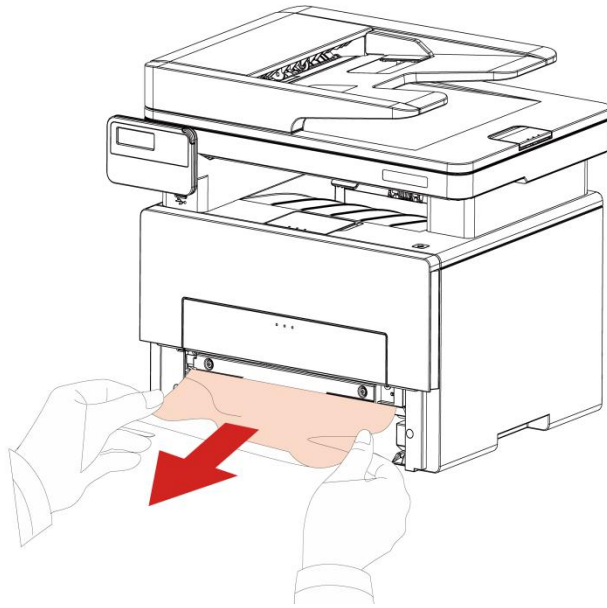

If you do not see paper in the area, stop and go to Step 3.

3. Open the front cover.

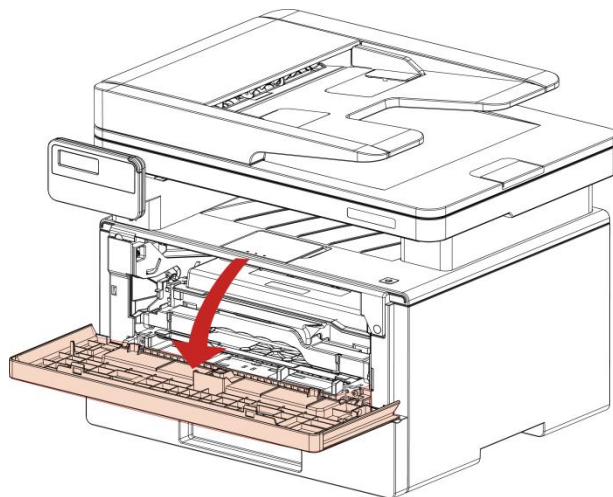

4. Take the laser toner cartridge out along the track. (For the purpose of preventing printing quality from affecting by the exposure of photosensitive drum, please put the laser toner cartridge inside the protection bag or wrap it with thick paper).

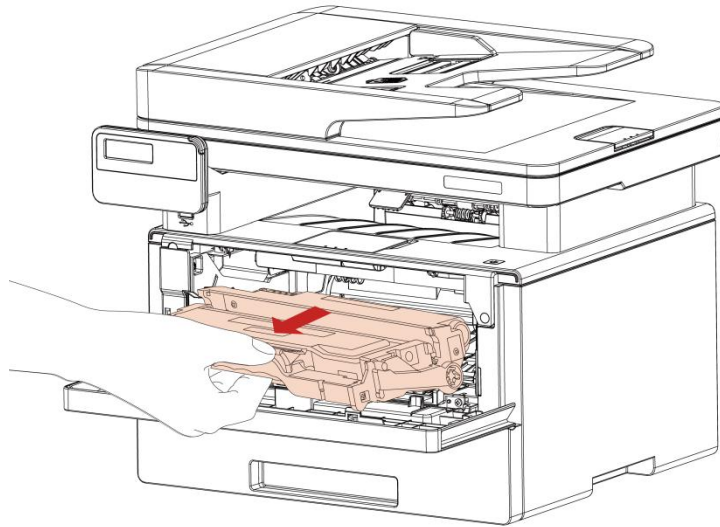

5. Gently pull the jammed paper out.

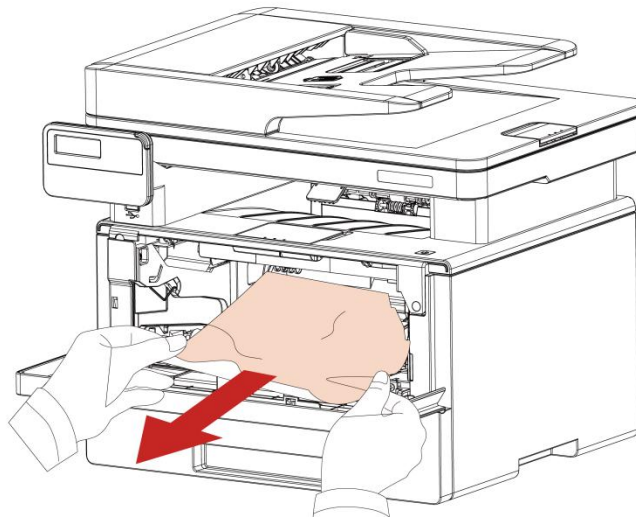

6. After taking out papers jammed, install the laser toner cartridge again and close the front cover, then the printer will recover printing.

Paper Jam in the Fuser Unit

Note: • When papers jammed in fuser unit are taken out, please pay attention and do not touch the shaded area shown below in order to avoid burns.

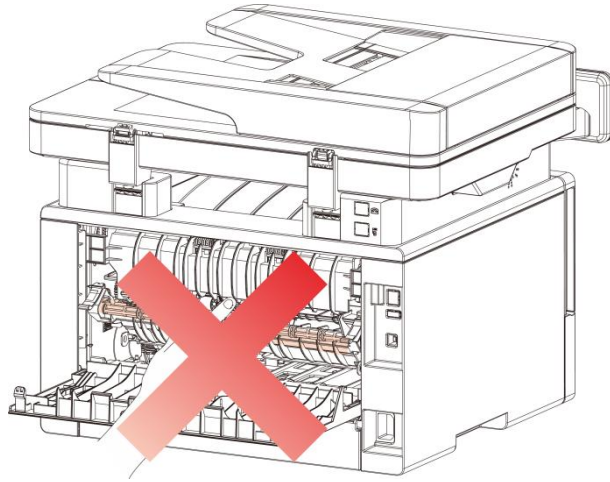

1. Open the front cover and then remove the laser toner cartridge along the guide rail.

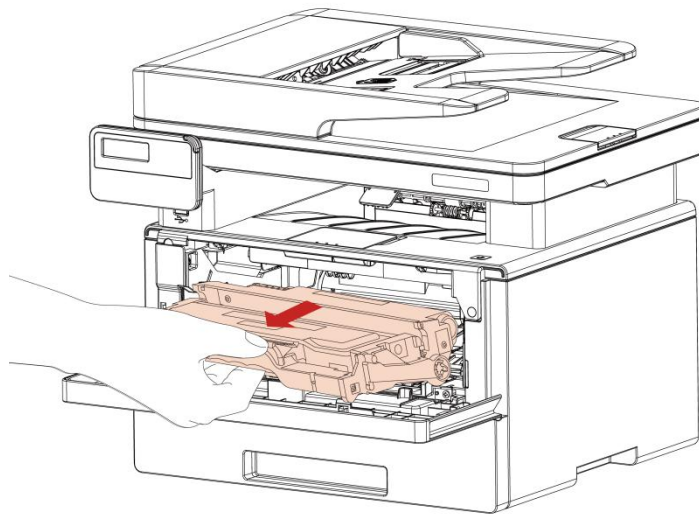

2. Open the rear cover.

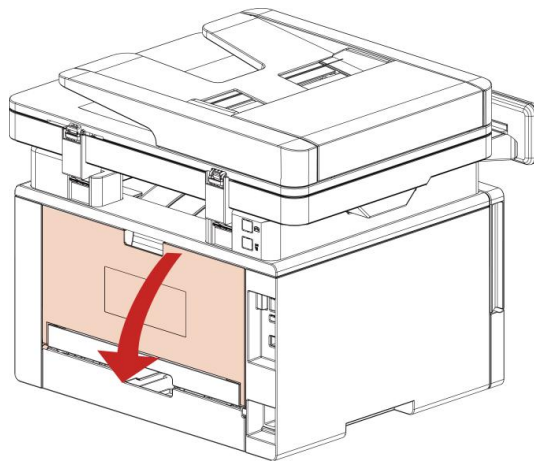

3. Open the fuser release unit by pressing the blue fuser release handles on both sides first and then the black paper guiding handle.

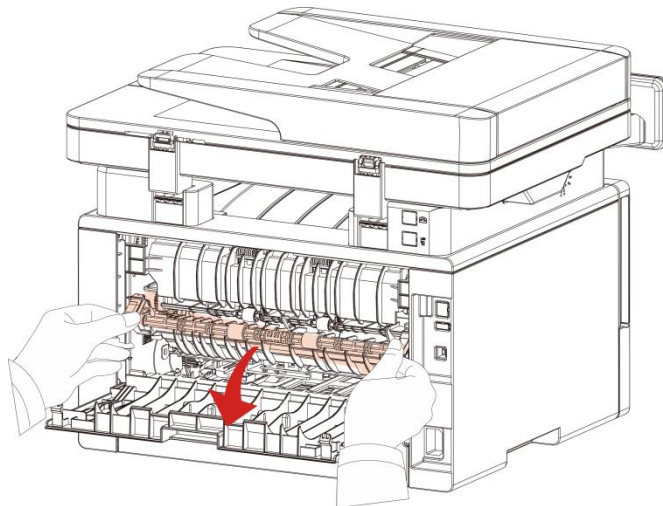

4. Gently pull the jammed paper out.

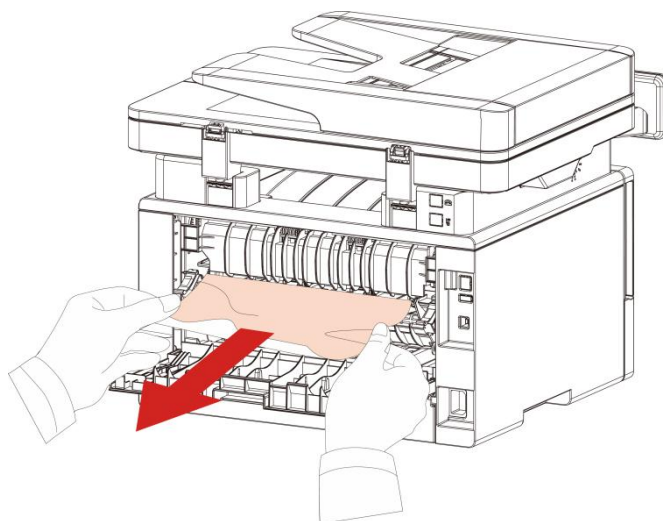

5. Close the back cover after removing the paper jammed.

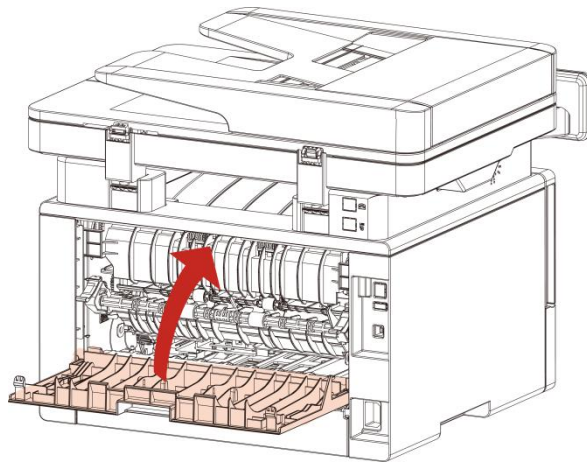

6. Install a new toner cartridge and then close the front cover; then, the printer will recover printing automatically.

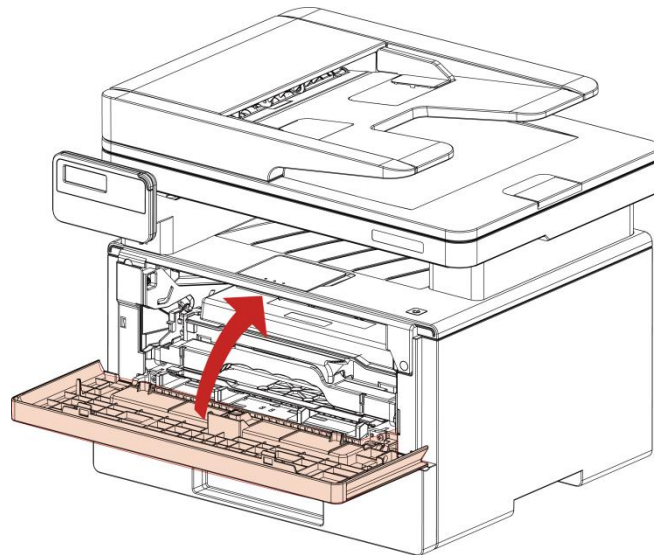

Duplex Unit Jam

1. Remove the duplex printing unit from the back of the printer.

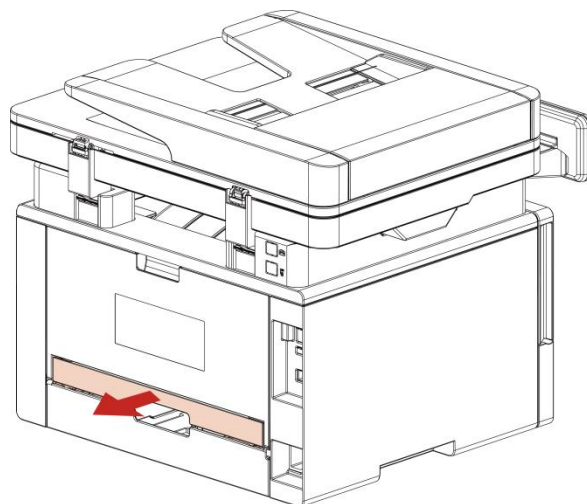

2. Remove the jammed paper from the duplex unit.

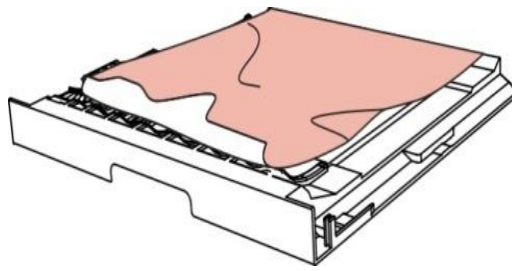

3. If the paper does not come out along with the duplex unit, open the tray and remove the jammed paper directly from the bottom.

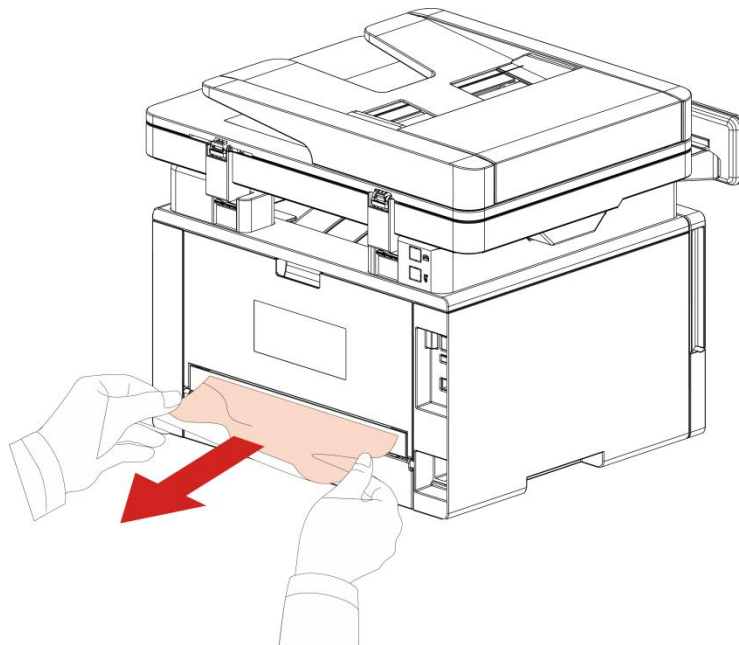

4. After taking papers jammed out, install the duplex unit back and inspect other parts to the product. If it can be ensured that there are no jammed papers, open and close the front cover and then the printer will recover printing automatically.

- Note:**
- After all papers jammed are taken out according to the above steps, close the front cover and tidy the papers in paper tray, then the printer will recover to print automatically.
 - If the printer still does not start printing, please check that all the jammed paper inside the printer has been cleared.
 - If you cannot remove the jammed paper yourself, please contact your local G&G authorized repair center or send the printer to the nearest G&G authorized service center for repair.
 - Printer appearance may differ because of various models and functions, so the schematic diagram is only for your reference.

A paper jam occurs on the automatic document feeder (ADF)

1. Open the ADF's top cover.

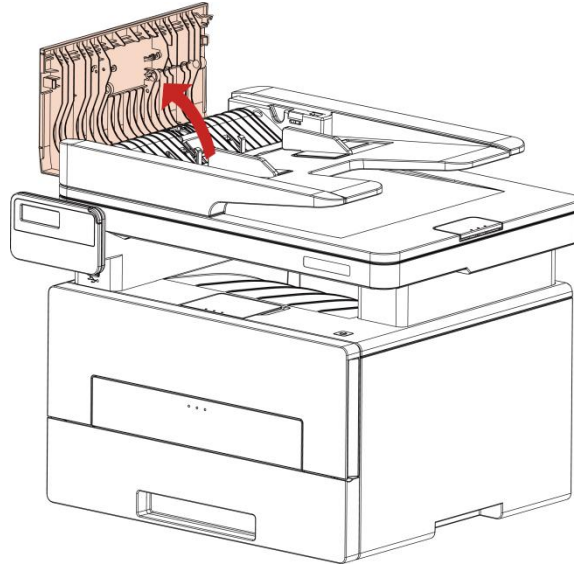

2. Remove the paper jammed from the ADF.

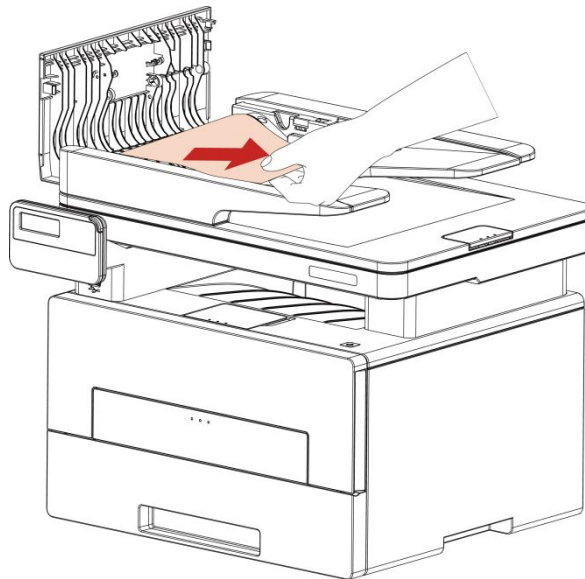

3. After removing the paper jammed, close the top cover and then the printer will be back to the ready state.

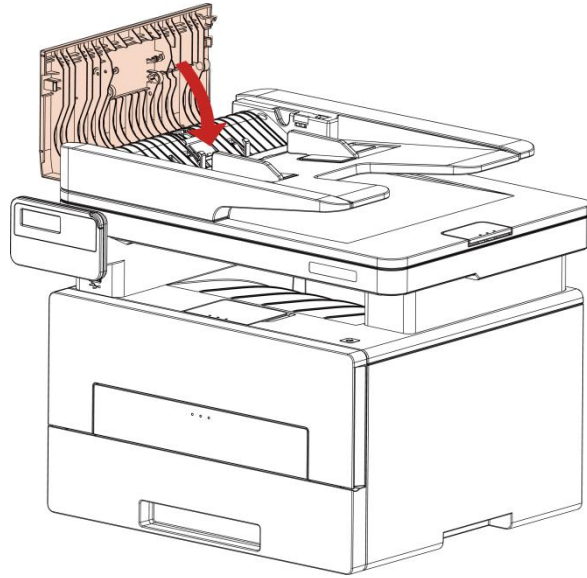

4. If it is difficult to remove the paper jammed, please try to open the scanner cover and remove it from the pressing block.

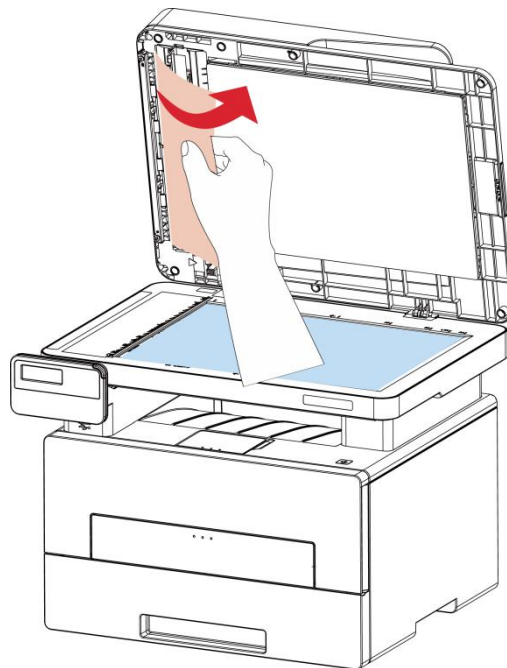

Software Failure

Problem	Solution
The printer icon will not be displayed in the "Device and Printer" folder.	Reinstall the printer driver. Please ensure that the USB cable and power cord are correctly connected.
The printer is in Ready mode but it will not perform any print job.	If the failure still exists after restarting the printer, please reinstall the printer driver. Make sure the network cable or USB cable is connected correctly.
Failed to install the driver	Check whether the print spooler service is enabled. Check the power supply and the connection of the printer.
The driver cannot be used if the IP address of the printer has been changed	Modify the port IP address of the printer driver. If the above method does not work, please reinstall the printer driver. It is recommended that a fixed IP address should be set to the network printer. In the DHCP network, it is recommended to bind the IP address with the MAC address of the printer.

Error Message

Error Message	Cause	Measure
No Laser Toner Cartridge Detected	The laser toner cartridge is installed incorrectly or laser toner cartridge is damaged.	The laser toner cartridge is installed correctly or new laser toner cartridge is replaced.
Toner Low (this prompt is displayed together with the standby picture alternately.)	The toner in cartridge runs low.	Please replace with a new toner cartridge.
Toner cartridge life expired.	The toner in cartridge runs out.	Please replace with a new toner cartridge.
Feed jam	The print paper is loaded incorrectly. The paper is outside of the specification range.	Please correctly load the print paper.
Printer paper jam	The print paper is loaded incorrectly.	Please correctly load the print paper.
Scanner is Busy	With other scan jobs.	Please cancel the current scan job or wait for the completion of other scan jobs.
Scan failed	Scanner internal failure.	Please contact G&G Customer Service.
No paper in ADF	If you have selected ADF as the scan source, this message appears when you start a copy or scan job without loading paper in the ADF.	Please put in the original properly.
Paper jam occurred on ADF	This prompt appears when there is a feed jam or feed failure in copying or scanning with the ADF.	Please remove the paper jam, arrange well and put originals into the ADF for scanning again.

Note: • If the problem persists, please contact the customer service center. See the Three Guarantees certificate for contact details.

Common Troubleshooting



Common Trouble

Trouble Type	Fault phenomenon	Cause	Solution
Problems in printing	Poor print quality	See details in Image Defects .	See details in Image Defects .
	Failed to copy	The scanner is damaged.	Please contact G&G Customer Service.
Problems in copying	Copy Image Abnormal	<ul style="list-style-type: none"> • The scanner is dirty or defective. • The toner cartridge is dirty or damaged. 	<ul style="list-style-type: none"> • Clean the scanner. • It is suggested to replace the original toner cartridge.
		<ul style="list-style-type: none"> • Power cord of the device is not properly connected. • The cable between the computer and the printer is not connected properly. • Error in specifying the print port. 	<ul style="list-style-type: none"> • Ensure proper connection of the power cord. • Please disconnect the printer cable and then connect it again. • Please check printer settings of the Windows to make sure the printing job could be sent to the correct port. If the computer is equipped with several ports, please be sure to connect the printer to the correct port.
Problems with the Printer	The printer does not work	<ul style="list-style-type: none"> • The printer is offline and User Guide of Printer is checked. • The printer has not recovered from an internal error, such as a paper jam, paper empty, etc. • Driver program of printer is not installed correctly. • The LCD screen prompts error messages. 	<ul style="list-style-type: none"> • Please make sure the printer is online without any abnormality. • Please remove errors to make the printer return to normal. • Please uninstall and then reinstall the printer driver.
		<ul style="list-style-type: none"> • The cable between the computer and the printer is not connected properly. • Driver program of printer is not installed correctly. • Printer internal failure. 	<ul style="list-style-type: none"> • Please disconnect the printer cable and then connect it again. • Please uninstall and then reinstall the printer driver.

Problems in scanning	Scanning error	<ul style="list-style-type: none"> • Data cable of the device is not properly connected. • The scan driver is installed incorrectly. • The LCD screen prompts error messages. 	<ul style="list-style-type: none"> • Ensure proper connection of the data cable. • Reinstall the scan driver.
Problems with Paper Handling	Paper feed failure	<ul style="list-style-type: none"> • The printer paper isn't put properly. • The print media is beyond the usage specification range. • The pickup roller is dirty. • Too many papers in paper tray. 	<ul style="list-style-type: none"> • Please install printing medium correctly; please print with manual feed tray if special printing medium is used to print. • Please use the print media within the specification range. • Please clean the pickup roller. Take the excessive papers out from paper tray; please print with manual feed tray if special printing medium is used to print.
Problems with Paper Handling	Paper Jam	<ul style="list-style-type: none"> • Too many papers in paper tray. • The print media is beyond the usage specification range. • There is foreign matter in the feed channel. • The pickup roller is dirty. • Internal parts failure. 	<ul style="list-style-type: none"> • Take the excessive papers out from paper tray; please print with manual feed tray if special printing medium is used to print. • Make sure to use the paper that meets specifications. please print with manual feed tray if special printing medium is used to print. • Clean the paper path. • Please clean the pickup roller.
Problems with Paper Handling	Print multipage feed	<ul style="list-style-type: none"> • Excessive static electricity on the print media. • The print media is damp or sticks together. • Internal parts failure. 	<ul style="list-style-type: none"> • Re-separate the print media to eliminate some static electricity. It is suggested that you use the recommended print media. • Separate the print media or use better quality and dry print media..

Note: • If the problem persists, please contact the customer service center. See the Three Guarantees certificate for contact details.

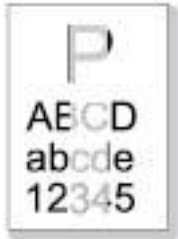
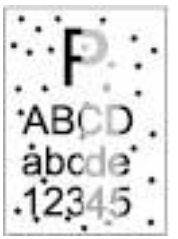
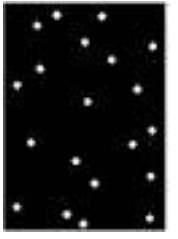
Image Defects

Problem	Cause	Solution
	<ul style="list-style-type: none"> • The print media does not meet the usage specifications, for example the media is damp or too rough. • The resolution in the print program is set too low, concentration setting is too low, or toner saving mode is ticked. • Toner cartridge is damaged. • Toner is low. 	<ul style="list-style-type: none"> • Please use proper print media within the specification range. • Set the resolution and concentration setting of program, or cancel ticking the save toner mode. • It is suggested to replace the original toner cartridge.
	<ul style="list-style-type: none"> • Dirty toner cartridge or toner leakage. • Toner cartridge is damaged. • The print media that does not meet usage specification is used. For example, the media is damp or too rough. • The paper path is dirty. • If toner spots appear when copying and scanning, the platen glass may be dirty. • The scanner is dirty or damaged. 	<ul style="list-style-type: none"> • It is suggested to replace the original toner cartridge. • Please use the print media within the specification range. • Clean the paper path. • Clean the platen glass.
	<ul style="list-style-type: none"> • The print media that does not meet usage specification is used. For example, the media is damp or too rough. • The paper path is dirty. • Inner damage of toner cartridge. • The reflective glass of the laser inside the printer is dirty. 	<ul style="list-style-type: none"> • Please use the print media within the specification range. • Clean the paper path. • It is suggested to replace the original toner cartridge. • Please clean the LSU lens.
	<ul style="list-style-type: none"> • The print media that does not meet usage specification is used. For example, the media is damp or too rough. • The printing paper medium set and paper medium placed are not consistent. • The inside of the printer is dirty. • Toner cartridge is damaged. • The parts inside the printer are damaged. 	<ul style="list-style-type: none"> • Please use printing medium within the specification scope, and use manual feed tray for printing in case of special medium. • Please print with corresponding paper medium. • Clean the inside of the printer. • It is suggested to replace the original toner cartridge.

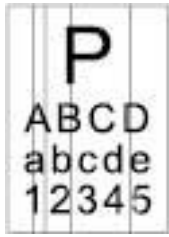

Black vertical stripes

- Dirty toner cartridge.
- Damaged inner parts of toner cartridge.
- The reflective glass of the laser inside the printer is dirty.
- The paper path is dirty.
- If black vertical stripes appear when copying or scanning, the scanner or the platen glass may be dirty.
- Scanner Light bulb has smudges.
- The scanner is damaged.
- Clean or replace toner cartridge
- Clean the mirror of the laser at the back of the printer.
- Clean the feed path of printer.
- Clean the scanner or the platen glass.



Black background(gray background)

- The print media that does not meet usage specification is used. For example, the media is damp or too rough.
- Dirty toner cartridge
- Damaged inner parts of toner cartridge.
- The paper path is dirty.
- The transfer voltage inside the printer is abnormal.
- Scanning exposure.
- If black background or gray background appears when copying and scanning, the platen glass may be dirty.
- Please use the print media within the specification range.
- Clean or replace toner cartridge
- Clean the paper path inside the printer.
- Please close the cover on the manuscript, and then carry out copying and scanning.
- Clean the platen glass.

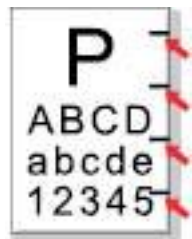

Cyclical traces appear

- Dirty toner cartridge.
- Damaged inner parts of toner cartridge.
- The fuser component is damaged.
- Clean or replace toner cartridge
- Please contact customer services center to replace to a new fuser assembly.



Skewed pages

- The printer paper isn't put properly.
- The feed channel of the printer is dirty.
- Make sure the print paper is placed correctly.
- Clean the paper path inside the printer.



Wrinkled paper

- The printer paper isn't put properly.
- The print media does not meet the usage specification.
- The feed channel of the printer is dirty.
- The fuser component is damaged.
- Make sure the print paper is placed correctly.
- Please use print media within the specification range.
- Clean the paper path inside the printer.
- Please contact customer services center to replace to a new fuser assembly.

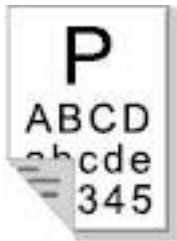

The back of the printout is dirty

- Dirty toner cartridge
- The transfer roller inside the printer is dirty.
- The transfer voltage inside the printer is abnormal.
- Clean or replace toner cartridge
- Clean the internal transfer part of the printer.



Whole page dark

- Toner cartridge is improperly installed.
- Inner damage of toner cartridge.
- Abnormal internal charging of machine or the toner cartridge is not charged.
- If all-black image appear when copying and scanning, maybe it is scanning exposure, and the cover on the manuscript is not properly closed.
- The scanner is damaged.
- Install ink cartridge correctly.
- It is suggested to replace the original toner cartridge.
- Please close the cover on the manuscript, and then carry out copying and scanning.



The toner does not adhere to the paper

- The print media that does not meet usage specification is used. For example, the media is damp or too rough.
- The inside of the printer is dirty.
- Toner cartridge is damaged.
- The parts inside the printer are damaged.
- Please use printing medium within the specification scope, and use manual feed tray for printing in case of special medium.
- Clean the inside of the printer.
- It is suggested to replace the original toner cartridge.

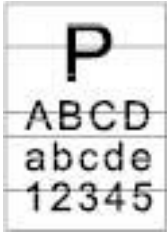

- The toner cartridge is not installed correctly.
- The toner cartridge may be damaged.
- The parts inside the printer are damaged.
- Install ink cartridge correctly.
- It is suggested to replace the original toner cartridge.

Horizontal stripes

Note: • The faults above can be mitigated by cleaning or replacing the cartridge. If the problem persists, please contact the customer service center. See the Three Guarantees certificate for contact details.

12 Product Specifications

Note: • Specification values are slightly different for different models of printers with different functions. These values are based on the initial data. For more information about the latest specification, please visit: www.gg-printer.ru.

Overview of the Specifications

Product Size(W*D*H)	415mm*365mm*350mm
Product weight (exclusive of the random toner cartridge and packaging)	10.46kg
Print Environment	Print temperature range:10~32°C Print humidity range:20%RH~80%RH
Power Voltage	110V Model: AC100-127V, 50Hz/60Hz,9A 220V Model: AC220-240V, 50Hz/60Hz,4.5A
Noise (acoustic pressure level)	Print/scan: ≤52dB(A) Standby: ≤30dB(A) Mute mode: ≤46dB(A)
Enter network standby time:	5 minute
Default automatic shutdown time(for EU only)	4 hours
Power Consumption	Network standby: the model with wireless function: ≤3W;the model without wireless function: ≤2W Sleep: ≤ 2W Standby: ≤50W Shutdown: ≤ 0.5W TEC: conforming to requirements of Chinese energy efficiency rating
Operating System	Microsoft WindowsXP(x86)/Windows7(x86/x64)/Windows8.1(x86/x64) / Windows10(x86/x64)/windows11(x64)/Windows server2012/2016/2019/2022(x64); macOS 10.10-14.3 ubuntu12.04(x86),ubuntu14.04(x64),ubuntu16.04(x64),ubuntu18.04(x64),Astra V1.6(x64),Centos 7(x86/x64),Redhat 8/ Centos 8(x64),Debian 10(x86/x64),Debian 11(x64),Mint 21.2(x64) iOS 13.0-16.0 Android 6.0-13.0
Communication interface	Hi-speed USB 2.0 IEEE802.3 10/100Base-Tx IEEE802.11b/g/n (support WPS)

Print Specifications

Print Speed	33ppm
Print Time of First Page	≤8.5sec
Print Language	PCL5e,PCL6,PS,PDF

Copy Specifications

Copy Speed	33cpm
FCOT	Flatbed <10 seconds
	ADF <12 seconds
Maximum Pages for Successive Print	99 pages
Zoom Ratio	25%~400%
Other Copy Functions	ID copy, Receipt copy, N-up copy, Clone copy, Poster Copy, Collated Copy, Manual duplex copying

Scan Specifications

Scan Type	Flatbed+ADF
Maximum Scan Size	Flatbed: 216×297mm
	ADF: 216×356 mm
Chromoscan	Yes
Scan Output Function	Scan to PC, E-mail, FTP and USB

